

©2019 Yamaha Motor Corporation, U.S.A.

F350
LF350

OWNER'S MANUAL

▲ Read this manual carefully before operating this outboard motor.

LIT-18626-11-25
6AW-28199-3B-E0

⚠ WARNING

The engine exhaust from this product contains chemicals known to the State of California to cause cancer, birth defects or other reproductive harm.

YAMAHA

LIT-CALIF-65-01

Les gaz d'échappement du moteur de ce produit contiennent des substances chimiques connues dans l'État de Californie pour provoquer le cancer, des anomalies congénitales et des troubles de la reproduction.

ZMU07696

©2019 Yamaha Motor Corporation, U.S.A.

Read this manual carefully before operating this outboard motor. Keep this manual onboard in a waterproof bag when boating. This manual should stay with the outboard motor if it is sold.

To the owner

Thank you for selecting a Yamaha outboard motor. This Owner's Manual contains information needed for proper operation, maintenance and care. A thorough understanding of these simple instructions will help you obtain maximum enjoyment from your new Yamaha. If you have any question about the operation or maintenance of your outboard motor, please consult a Yamaha dealer.

In this Owner's Manual particularly important information is distinguished in the following ways.

 : This is the safety alert symbol. It is used to alert you to potential personal injury hazards. Obey all safety messages that follow this symbol to avoid possible injury or death.

EWM00782

WARNING

A WARNING indicates a hazardous situation which, if not avoided, could result in death or serious injury.

ECM00702

NOTICE

A NOTICE indicates special precautions that must be taken to avoid damage to the outboard motor or other property.

TIP:

A TIP provides key information to make procedures easier or clearer.

Yamaha continually seeks advancements in product design and quality. Therefore, while this manual contains the most current product information available at the time of printing, there may be minor discrepancies between your machine and this manual. If there is any question concerning this manual, please consult your Yamaha dealer.

To ensure long product life, Yamaha recommends that you use the product and perform the specified periodic inspections and maintenance by correctly following the instructions in the owner's manual. Any damage resulting from neglect of these instructions is not covered by warranty.

Some countries have laws or regulations restricting users from taking the product out of the country where it was purchased, and it may be impossible to register the product in the destination country. Additionally, the warranty may not apply in certain regions. When planning to take the product to another country, consult the dealer where the product was purchased for further information.

If you purchased this outboard motor used, see your Yamaha dealer to have it registered in your name in Yamaha records.

TIP:

The F350CC, LF350CC and the standard accessories are used as a base for the explanations and illustrations in this manual. Therefore some items may not apply to every model.

F350, LF350
OWNER'S MANUAL
©2016 by Yamaha Motor Co., Ltd.
1st Edition, February 2016
All rights reserved.
Any reprinting or unauthorized use
without the written permission of
Yamaha Motor Co., Ltd.
is expressly prohibited.
Printed in Japan

Table of contents

Safety information	1	Emission control information	16
Outboard motor safety	1	Star labels	16
Propeller.....	1	Components	18
Rotating parts.....	1	Components diagram	18
Hot parts	1	Optional items	19
Electric shock.....	1	Yamaha Security System (Y-COP).....	21
Power trim and tilt	1	Digital electronic control.....	21
Engine shut-off cord (lanyard).....	1	Digital electronic control-active indicator.....	21
Gasoline.....	1	Digital electronic control-alert indicator	22
Gasoline exposure and spills	1	Control lever.....	22
Carbon monoxide.....	1	Neutral interlock trigger.....	23
Modifications	1	Free throttle switch.....	23
Boating safety	1	Throttle friction adjuster	24
Alcohol and drugs	1	Engine selector switch	25
Personal flotation devices (PFDs).....	1	Engine shut-off cord (lanyard) and clip	25
People in the water	1	Main switch	26
Passengers	1	Start/Stop switch panel	26
Overloading.....	2	All Start/Stop switch panel	27
Avoid collisions	2	Power trim and tilt switch on digital electronic control.....	27
Weather	2	Power trim and tilt switch on bottom cowling	27
Accident reporting.....	2	Power trim and tilt switches	27
Boat education and training	2	Tilt limiter.....	28
Passenger training.....	2	Tilt support lever for power trim and tilt model	28
Boating safety publications	2	Cowling lock lever	28
Laws and regulations	2	Flushing device	28
Boating organizations	2	Fuel filter	29
Basic boating rules (Rules of the road).....	3	Instruments and indicators	30
Steering and sailing rules and sound signals.....	3	6Y9 Multifunction Color Gauge.....	30
Rules when encountering vessels	3	Yamaha Security System indicator (optional)	30
Other special situations.....	4	Engine warm-up indicator	30
General information	6	Engine synchronization indicator	30
Identification numbers record.....	6	Overheat alert	30
Outboard motor serial number	6	Low oil pressure-alert.....	31
Digital electronic control serial number	6	Water separator alert	31
Key number.....	6	Low battery voltage-alert.....	31
EC Declaration of Conformity (DoC).....	7	Engine trouble alert.....	32
CE Marking	7	6YC Multifunction meter	32
Compliance mark and manufactured date label	7	6Y8 Multifunction meters	34
Read manuals and labels	9	Engine control system	37
Warning labels	9	Alert system.....	37
Specifications and requirements	12	Digital Electronic Control alert.....	37
Specifications	12	Overheat alert	37
Installation requirements	13	Low oil pressure alert.....	38
Boat horsepower rating.....	13	Water separator alert	39
Mounting motor	13	Installation	40
Digital electronic control requirements.....	13	Installation	40
Battery requirements.....	13	Mounting the outboard motor.....	40
Battery specifications	13	Operation	41
Propeller selection	14	First-time operation.....	41
Counter rotation models.....	14	Fill engine oil	41
Start-in-gear protection	14	Breaking in engine	41
Engine oil requirements	14	Getting to know your boat.....	41
Fuel requirements	14	Checks before starting engine.....	41
Gasoline.....	14	Fuel level.....	41
Gasoline Additives	15	Removing top cowling.....	41
Anti-fouling paint	15		
Outboard motor disposal requirements.....	16		
Emergency equipment	16		

Table of contents

Fuel system.....	42	Checking propeller.....	68
Controls.....	42	Removing propeller.....	68
Engine shut-off cord (lanyard).....	42	Installing propeller.....	69
Engine oil.....	42	Changing gear oil.....	69
Engine.....	43	Inspecting and replacing anode(s).....	70
Flushing device.....	43	Checking battery (for electric start models).....	71
Installing top cowling.....	43	Connecting the battery.....	71
Checking power trim and tilt system.....	44	Disconnecting the battery.....	72
Battery.....	44	Storing the battery.....	72
Filling fuel.....	44	Trouble Recovery.....	73
Operating engine.....	45	Troubleshooting.....	73
Sending fuel.....	45	Temporary action in emergency.....	75
Starting engine.....	45	Impact damage.....	75
Checks after starting engine.....	47	Running in an emergency (multiple engines).....	75
Cooling water.....	47	Replacing fuse.....	75
Warming up engine.....	47	Power trim and tilt will not operate.....	76
Electric start models.....	47	Water separator-alert indicator blinks while cruising.....	76
Checks after engine warm up.....	47	Treatment of submerged motor.....	77
Shifting.....	47	Consumer information (For North America).....	78
Stop switches.....	47	YAMAHA FOUR-STROKE OUTBOARD MOTOR THREE-YEAR LIMITED WARRANTY.....	78
Selecting outboard motor (triple engine).....	48	IMPORTANT WARRANTY INFORMATION IF YOU USE YOUR YAMAHA OUTSIDE THE U.S.A. OR CANADA.....	80
Shifting.....	49	INDEX.....	81
Stopping boat.....	50		
Operating the port / center / starboard engine.....	50		
Boat direction.....	53		
Trolling.....	55		
Adjusting trolling speed.....	55		
Stopping engine.....	55		
Procedure for stopping engine.....	55		
Trimming outboard motor.....	56		
Adjusting trim angle (Power trim and tilt).....	56		
Adjusting boat trim.....	57		
Tilting up and down.....	57		
Procedure for tilting up (power trim and tilt models).....	57		
Procedure for tilting down (power trim and tilt models).....	58		
Shallow water.....	59		
Power trim and tilt models.....	59		
Operating in other conditions.....	60		
Maintenance.....	61		
Transporting and storing outboard motor.....	61		
Storing outboard motor.....	61		
Conditioning and stabilizing gasoline.....	61		
Procedure.....	61		
Lubrication.....	61		
Cleaning and anticorrosion measures.....	62		
Flushing power unit.....	62		
Checking painted surface of outboard motor.....	62		
Periodic maintenance.....	62		
Replacement parts.....	62		
Maintenance interval guidelines.....	63		
Maintenance chart 1.....	64		
Maintenance chart 2.....	65		
Maintenance chart 3.....	65		
Greasing.....	66		
Inspecting spark plug.....	66		
Inspecting engine idle speed.....	67		
Changing engine oil.....	68		
Inspecting wiring and connectors.....	68		

Safety information

EMU33623

Outboard motor safety

Observe these precautions at all times.

EMU36502

Propeller

People can be injured or killed if they come in contact with the propeller. The propeller can keep moving even when the motor is in neutral, and sharp edges of the propeller can cut even when stationary.

- Stop the engine when a person is in the water near you.
- Keep people out of reach of the propeller, even when the engine is off.

EMU33631

Rotating parts

Hands, feet, hair, jewelry, clothing, PFD straps, etc. can become entangled with internal rotating parts of the engine, resulting in serious injury or death.

Keep the top cowling in place whenever possible. Do not remove or replace the cowling with the engine running.

Only operate the engine with the cowling removed according to the specific instructions in the manual. Keep hands, feet, hair, jewelry, clothing, PFD straps, etc. away from any exposed moving parts.

EMU33641

Hot parts

During and after operation, engine parts are hot enough to cause burns. Avoid touching any parts under the top cowling until the engine has cooled.

EMU33651

Electric shock

Do not touch any electrical parts while starting or operating the engine. They can cause shock or electrocution.

EMU33661

Power trim and tilt

Body parts can be crushed between the motor and the clamp bracket when the motor is trimmed or tilted. Keep body parts out of this area at all times. Be sure no one is in this area before operating the power trim and tilt mechanism.

The power trim and tilt switches operate even when the main switch is off. Keep people away from the switches whenever working around the motor.

Never get under the lower unit while it is tilted, even when the tilt support lever is locked. Severe injury could occur if the outboard motor accidentally falls.

EMU33672

Engine shut-off cord (lanyard)

Attach the engine shut-off cord so that the engine stops if the operator falls overboard or leaves the helm. This prevents the boat from running away under power and leaving people stranded, or running over people or objects.

Always attach the engine shut-off cord to a secure place on your clothing or your arm or leg while operating. Do not remove it to leave the helm while the boat is moving. Do not attach the cord to clothing that could tear loose, or route the cord where it could become entangled, preventing it from functioning.

Do not route the cord where it is likely to be accidentally pulled out. If the cord is pulled during operation, the engine

will shut off and you will lose most steering control. The boat could slow rapidly, throwing people and objects forward.

EMU33811

Gasoline

Gasoline and its vapors are highly flammable and explosive. Always, refuel according to the procedure on page 45 to reduce the risk of fire and explosion.

EMU33821

Gasoline exposure and spills

Take care not to spill gasoline. If gasoline spills, wipe it up immediately with dry rags. Dispose of rags properly.

If any gasoline spills onto your skin, immediately wash with soap and water. Change clothing if gasoline spills on it.

If you swallow gasoline, inhale a lot of gasoline vapor, or get gasoline in your eyes, get immediate medical attention.

Never siphon fuel by mouth.

EMU33901

Carbon monoxide

This product emits exhaust gases which contain carbon monoxide, a colorless, odorless gas which may cause brain damage or death when inhaled. Symptoms include nausea, dizziness, and drowsiness. Keep cockpit and cabin areas well ventilated. Avoid blocking exhaust outlets.

EMU33781

Modifications

Do not attempt to modify this outboard motor. Modifications to your outboard motor may reduce safety and reliability, and render the outboard unsafe or illegal to use.

EMU33741

Boating safety

This section includes a few of the many important safety precautions that you should follow when boating.

EMU33711

Alcohol and drugs

Never operate after drinking alcohol or taking drugs. Intoxication is one of the most common factors contributing to boating fatalities.

EMU40281

Personal flotation devices (PFDs)

Have an approved PFD on board for every occupant. Yamaha recommends that you must wear a PFD whenever boating. At a minimum, children and non-swimmers should always wear PFDs, and everyone should wear PFDs when there are potentially hazardous boating conditions.

EMU33732

People in the water

Always watch carefully for people in the water, such as swimmers, skiers, or divers, whenever the engine is running. When someone is in the water near the boat, shift into neutral and stop the engine.

Stay away from swimming areas. Swimmers can be hard to see.

The propeller can keep moving even when the motor is in neutral. Stop the engine when a person is in the water near you.

EMU33752

Passengers

Consult your boat manufacturer's instructions for details about appropriate passenger locations in your boat and be sure all passengers are positioned properly before acceler-

ating and when operating above an idle speed. Standing or sitting in non-designated locations may result in being thrown either overboard or within the boat due to waves, wakes, or sudden changes in speed or direction. Even when people are positioned properly, alert your passengers if you must make any unusual maneuver. Always avoid jumping waves or wakes.

EMU33762

Overloading

Do not overload the boat. Consult the boat capacity plate or boat manufacturer for maximum weight and number of passengers. Be sure that weight is properly distributed according to the boat manufacturer's instructions. Overloading or incorrect weight distribution can compromise the boats handling and lead to an accident, capsizing or swamping.

EMU33773

Avoid collisions

Scan constantly for people, objects, and other boats. Be alert for conditions that limit your visibility or block your vision of others.

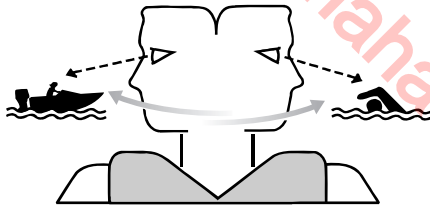

ZMU06025

Operate defensively at safe speeds and keep a safe distance away from people, objects, and other boats.

- Do not follow directly behind other boats or waterskiers.
- Avoid sharp turns or other maneuvers that make it hard for others to avoid you or understand where you are going.
- Avoid areas with submerged objects or shallow water.
- Ride within your limits and avoid aggressive maneuvers to reduce the risk of loss of control, ejection, and collision.
- Take early action to avoid collisions. Remember, boats do not have brakes, and stopping the engine or reducing throttle can reduce the ability to steer. If you are not sure that you can stop in time before hitting an obstacle, apply throttle and turn in another direction.

EMU33791

Weather

Stay informed about the weather. Check weather forecasts before boating. Avoid boating in hazardous weather.

EMU44161

Accident reporting

Boat operators are required by law to file a Boating Accident Report with their boating law enforcement agency if their boat is involved in any of the following accidents:

1. There is loss of life or probable loss of life.
2. There is personal injury that requires medical attention beyond first aid.
3. There is property damage to boats or other property over a certain amount.

4. There is complete loss of a boat.

Contact local law enforcement personnel if a report is necessary.

EMU44171

Boat education and training

For U.S.A.

Operators should take a boating safety course. This may be required in your state. Many of the organizations listed in the next section can provide information about courses in your area.

You may also want to consider an Internet-based program for basic boater education. The Online Boating Safety Course provided by the BoatU.S. Foundation, is approved by the National Association of State Boating Law Administrators (NASBLA) and recognized by the United States Coast Guard. Most, but not all, states accept this course to meet their minimum requirements. While it cannot replace an in-depth course such as one offered by the U.S. Coast Guard, U.S. Power Squadron, or other organization, this online course does provide a general overview of the basics in boating safety, requirements, navigation, and operation. Upon successful completion of the course, the user can download a certificate of completion immediately or, for a small charge, request one by mail. To take this free course, go to boat.us.org.

For Canada

All operators of pleasure craft must illustrate competency by means of a Pleasure Craft Operators Card with the exception of Personal Water Craft used for rental purposes which require a rental checklist be completed. Pleasure Craft Operators Cards can be obtained following the completion of a competency course, with an on-line option. Details can be found on Transport Canada's website. www.tc.gc.ca

EMU33881

Passenger training

Make sure at least one other passenger is trained to operate the boat in the event of an emergency.

EMU33891

Boating safety publications

Be informed about boating safety. Additional publications and information can be obtained from many boating organizations.

EMU33591

Laws and regulations

Know the marine laws and regulations where you will be boating- and obey them. Several sets of rules prevail according to geographic location, but all are basically the same as the International Rules of the Road. The rules presented in the following section are condensed- and have been provided for your convenience only.

Contact the U.S. Coast Guard, the National Association of State Boating Law Administrators, or your local Power Squadron for a complete set of rules governing the waters in which you will be using your boat.

EMU44740

Boating organizations

The following organizations provide boating safety training and information about boating safety and laws.

Safety information

In the U.S.A.

United States Coast Guard

Consumer Affairs Staff (G-BC)
Office of Boating, Public, and Consumer Affairs
U.S. Coast Guard Headquarters
Washington, D.C. 20593-0001
<http://www.uscgboating.org/>

United States Power Squadrons

1-888-FOR-USPS (1-888-367-8777)
<http://www.usps.org/>

Boat Owners Association of The United States

1-800-336-BOAT (1-800-336-2628)
<http://www.boatus.com/>

National Association of State Boating Law Administrators (NASBLA)

1500 Leestown Road, Suite 330
Lexington, KY 40511 859-225-9497
<http://www.nasbla.org/>

National Marine Manufacturers Association (NMMA)

200 East Randolph Drive
Suite 5100
Chicago, IL 60601
<http://www.nmma.org/>

Marine Retailers Association of America

155 N. Michigan Ave. Chicago,
IL 60304
<http://www.mraa.com/>

In Canada

National Marine Manufacturers Association Canada

14 McEwan Drive
Suite 8
Bolton, ON
L7E 1H1
<http://www.nmma.org/>

In Australia

Boating Industry Association of Australia

<http://www.biaa.com.au/>

In New Zealand

NZ Marine Industry Association

<http://www.nzmarine.com/>

EMU33692

Basic boating rules (Rules of the road)

Just as there are rules that apply when you are driving on streets and highways, there are waterway rules that apply when you are driving your boat. These rules are used internationally. (For U.S.A.: and are also enforced by the United States Coast Guard and local agencies.) You should be aware of these rules, and follow them whenever you encounter another vessel on the water.

EMU33702

Steering and sailing rules and sound signals

Whenever two vessels on the water meet one another, one vessel has the right-of-way; it is called the “stand-on” vessel. The vessel that does not have the right-of-way is called the “give-way” or “burdened” vessel. These rules determine which vessel has the right-of-way, and what each vessel should do.

Stand-on vessel

The vessel with the right-of-way has the duty to continue its course and speed, except to avoid an immediate collision. When you maintain your direction and speed, the other vessel will be able to determine how best to avoid you.

Give-way vessel

The vessel that does not have the right-of-way has the duty to take positive and timely action to stay out of the way of the Stand-On vessel. Normally, you should not cross in front of the vessel with the right-of-way. You should slow down or change directions briefly and pass behind the other vessel. You should always move in such a way that the operator of the other vessel can see what you are doing.

“The general prudential rule”

This rule is called Rule 2 in the International Rules and says,

“In obeying and construing these rules due regard shall be had to all dangers of navigation and collision, and to any special circumstances, which may render a departure from the above rules necessary in order to avoid immediate danger.”

In other words, follow the standard rules except when a collision will occur unless both vessels try to avoid each other. If that is the case, both vessels become “Give-Way” vessels.

EMU25522

Rules when encountering vessels

There are three main situations that you may encounter with other vessels which could lead to a collision unless the Steering Rules are followed:

Meeting: (you are approaching another vessel head-on)

Crossing: (you are traveling across the other vessel’s path)

Overtaking: (you are passing or being passed by another vessel)

In the following illustration, your boat is in the center. You should give the right-of-way to any vessels shown in white area (you are the Give-Way vessel). Any vessels in the shaded area must yield to you (they are the Give-Way vessels). Both you and the meeting vessel must alter course to avoid each other.

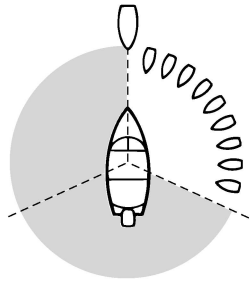

ZMU01705

Meeting

If you are meeting another power vessel head on, and are close enough to run the risk of collision, neither of you has the right-of-way. Both of you should alter course to avoid an accident. You should keep the other vessel on your port (left) side. This rule doesn't apply if both of you will clear one another if you continue on your set course and speed.

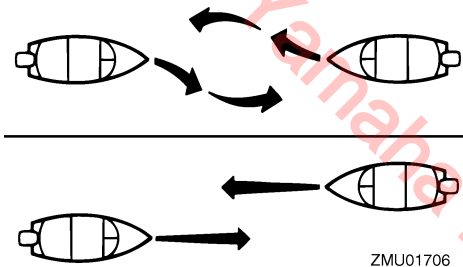

ZMU01706

Crossing

When two power driven vessels are crossing each other's path close enough to run the risk of collision, the vessel which has the other on the starboard (right) side must keep out of the way of the other. If the other vessel is on your right, you must keep out of its way; you are the Give-Way vessel. If the other vessel is on your port (left) side, remember that you should maintain course and direction, provided the other vessel gives you the right-of-way as it should.

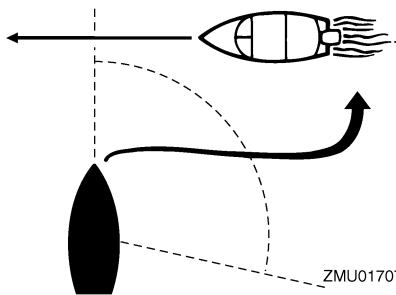

ZMU01707

Overtaking

If you are passing another vessel, you are the "Give-Way" vessel. This means that the other vessel is expected to maintain its course and speed. You must stay out of its way until you are clear of it. Likewise, if another vessel is passing you, you should maintain your speed and direction so that the other vessel can steer itself around you.

EMU25532

Other special situations

There are three other rules you should be aware of when driving your boat around other vessels.

Narrow channels and bends

When navigating in narrow channels, you should keep to the right when it is safe and practical to do so. If the operator of a power-driven vessel is preparing to go around a bend that may obstruct the view of other water vessels, the operator should sound a prolonged blast on the whistle (4 to 6 seconds). If another vessel is around the bend, it too should sound the whistle. Even if no reply is heard, however, the vessel should still proceed around the bend with caution. If you navigate such waters with your boat, you will need to carry a portable air horn, available from local marine supply stores.

Fishing vessel right-of-way

All vessels that are fishing with nets, lines or trawls are considered to be "fishing vessels" under the International Rules. Vessels with trolling lines are not considered fishing vessels. Fishing vessels have the right-of-way regardless of position. Fishing vessels cannot, however, impede the passage of other vessels in narrow channels.

Sailing vessel right-of-way

Sailing vessels should normally be given the right-of-way. The exceptions to this are:

1. When the sailing vessel is overtaking the power-driven vessel, the power-driven vessel has the right-of-way.
2. Sailing vessels should keep clear of any fishing vessel.
3. In a narrow channel, a sailing vessel should not hamper the safe passage of a power-driven vessel that can navigate only in such a channel.

Reading buoys and other markers

The waters of the United States are marked for safe navigation by the lateral system of buoyage. Simply put, buoys and markers have an arrangement of shapes, colors, numbers and lights to show which side of the buoy a boater should pass on when navigating in a particular direction. The markings on these buoys are oriented from the perspective of being entered from seaward (the boater is going towards the port). This means that red buoys are passed on the starboard (right) side when proceeding from open water into port, and black buoys are to port (left) side. When navigating out of port, your position with respect to the buoys should be reversed; red buoys should be to port and black buoys to starboard.

Many bodies of water used by boaters are entirely within the boundaries of a particular state. The Uniform State Waterway Marking System has been devised for these waters. This system uses buoys and signs with distinctive shapes and colors to show regulatory or advisory information. These markers are white with black letters and orange borders. They signify speed zones, restricted areas, danger areas, and general information.

Remember, markings may vary by geographic location. Always consult local boating authorities before driving your boat in unfamiliar waters.

! Safety information

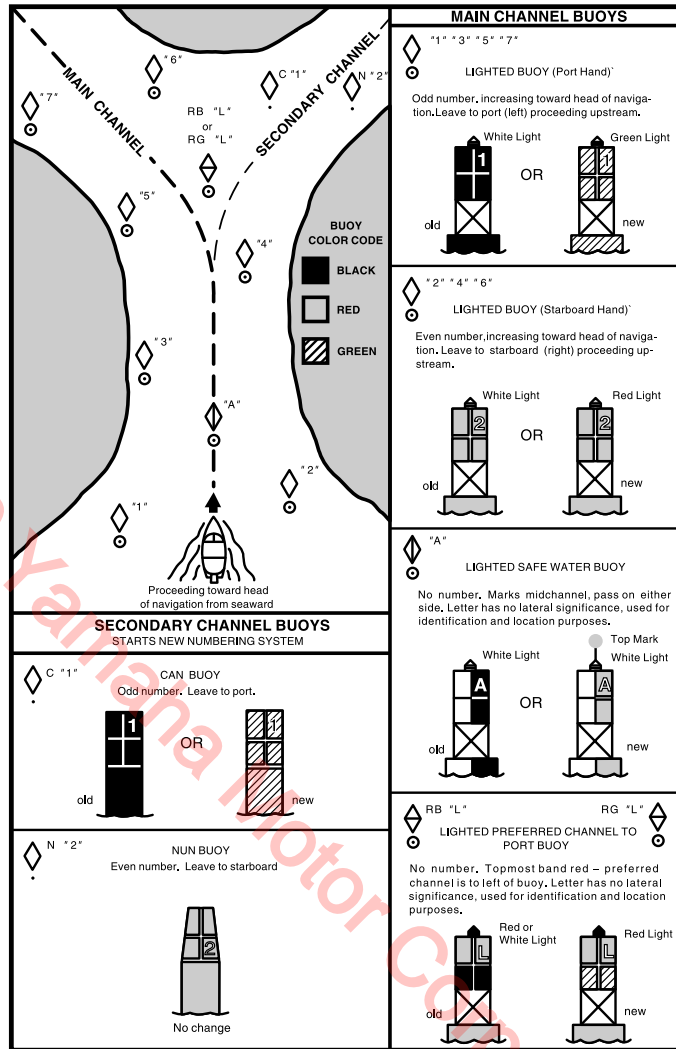

ZMU01708

EMU25172

Identification numbers record

EMU25186

Outboard motor serial number

The outboard motor serial number is stamped on the label attached to the port side of the clamp bracket.

Record your outboard motor serial number in the spaces provided to assist you in ordering spare parts from your Yamaha dealer or for reference in case your outboard motor is stolen.

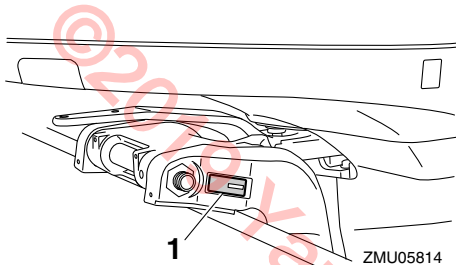

ZMU05814

1. Outboard motor serial number location

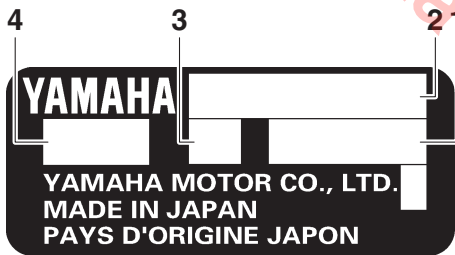

ZMU01692

1. Serial number
2. Model name
3. Motor transom height
4. Approved model code

EMU34944

Digital electronic control serial number

The digital electronic control serial number is stamped on the label attached to the digital electronic control box.

Record your digital electronic control serial number in the spaces provided to assist you in newly connecting the digital electronic control to the outboard motor.

TIP:

Consult your Yamaha dealer if you have any questions concerning the digital electronic control serial number.

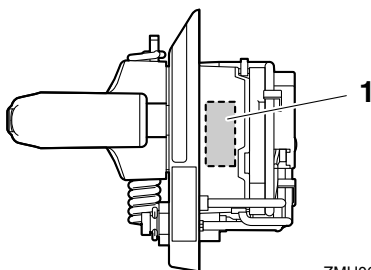

ZMU06224

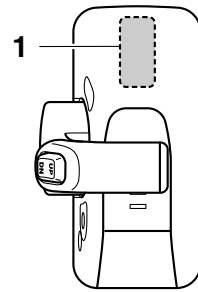

ZMU05885

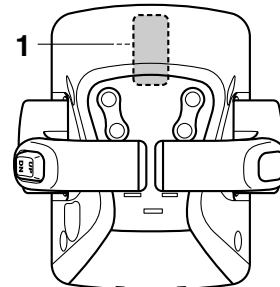

ZMU05887

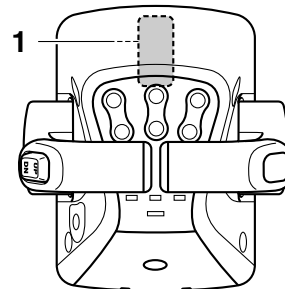

ZMU05958

1. Digital electronic control serial number location

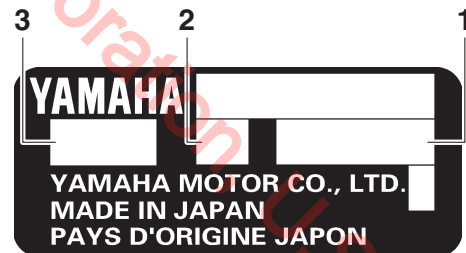

ZMU05917

1. Serial number
2. Type
3. Approved model code

EMU25192

Key number

If a main key switch is equipped with the motor, the key identification number is stamped on your key as shown in the illustration. Record this number in the space provided for reference in case you need a new key.

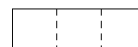

ZMU01693

General information

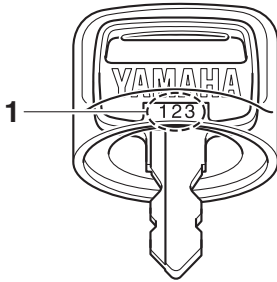

ZMU01694

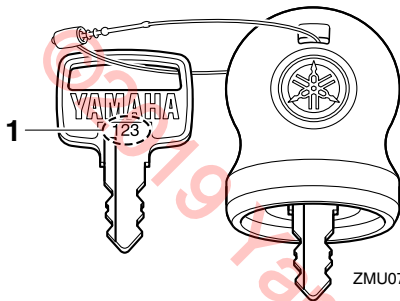

ZMU07133

1. Key number

EMU38981

EC Declaration of Conformity (DoC)

This declaration is included with outboard motors that conform to European regulations.

This outboard motor conforms to certain portions of the European Parliament directive relating to machinery. Each conformed outboard motor accompanied with EC DoC. EC DoC contains the following information;

- Name of Engine Manufacture
- Model name
- Product code of model (Approved model code)
- Code of conformed directives

EMU38995

CE Marking

This label is affixed to outboard motors that conform to European regulations.

Outboard motors affixed with this "CE" marking conform with the directives of; 2006/42/EC, 94/25/EC - 2003/44/EC, 2014/30/EU, and 2004/108/EC, 2013/53/EU.

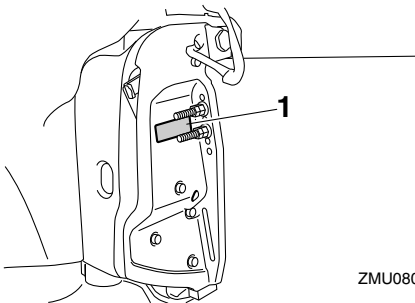

ZMU08050

1. CE marking location



ZMU06040

EMU46132

Compliance mark and manufactured date label

Engines affixed with this label conform to the regulations for each country.

This label is affixed to the clamp bracket or swivel bracket.

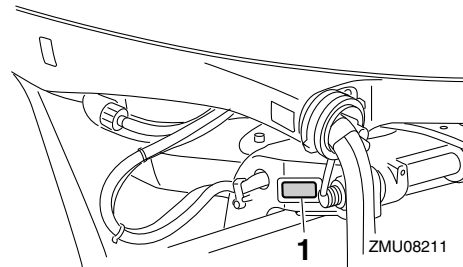

ZMU08211

1. Compliance mark and manufactured date label location

Regulatory Compliance Mark (RCM)

Engines affixed with this mark conform to certain portion(s) of the Australian Radio Communications Act.

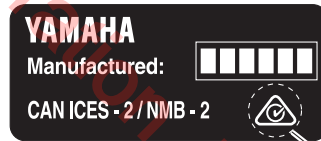

ZMU08190

1. Regulatory Compliance Mark (RCM)

ICES-002 Compliance Label

Engines affixed with this mark meet all requirements of the Canadian Interference Causing Equipment Regulations.

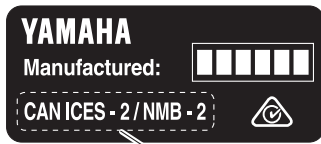

ZMU08191

1. ICES-002 Compliance Label

Manufactured date

The manufactured date is stamped on the label for the engines that conform to the regulations for U.S. Environmental Protection Agency (EPA). The models that manufactured exclusively for the Oceanian countries may not have manufactured date on the label.

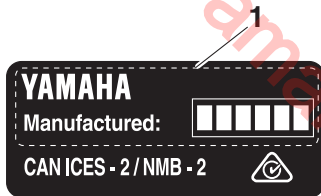

ZMU08192

1. Manufactured date

General information

EMU33524

Read manuals and labels

Before operating or working on this outboard motor:

- Read this manual.
 - Read any manuals supplied with the boat.
 - Read all labels on the outboard motor and the boat.
- If you need any additional information, contact your Yamaha dealer.

EMU33836

Warning labels

If these labels are damaged or missing, contact your Yamaha dealer for replacements.

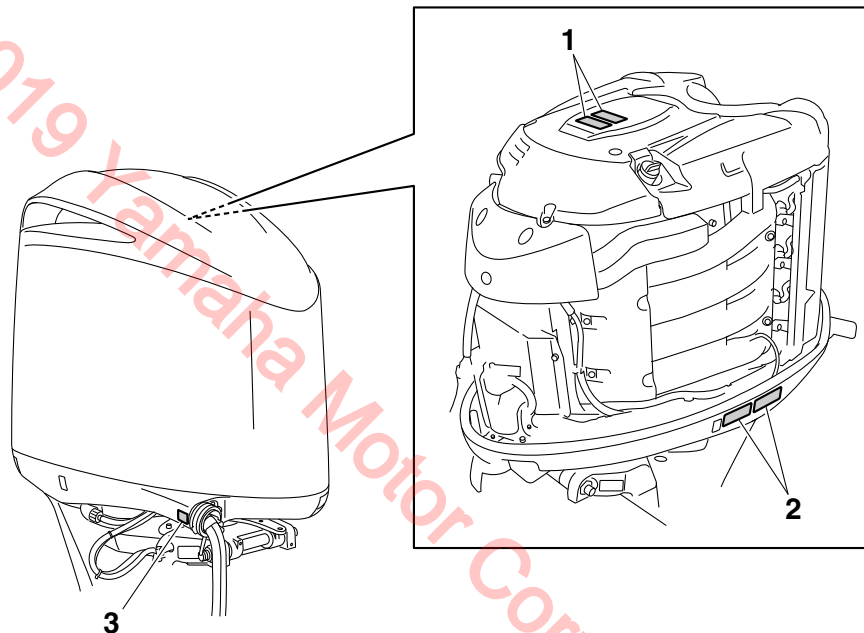

ZMU05950

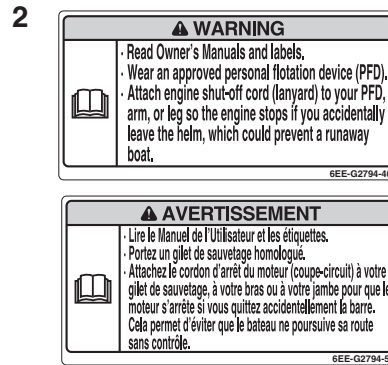
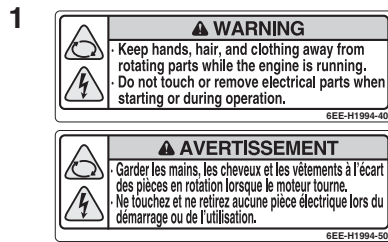

EMU34652

Contents of labels

The above warning labels mean as follows.

1

EWM01682

⚠ WARNING

- Keep hands, hair, and clothing away from rotating parts while the engine is running.
- Do not touch or remove electrical parts when starting or during operation.

2

EWM01672

⚠ WARNING

- Read Owner's Manuals and labels.
- Wear an approved personal flotation device (PFD).
- Attach engine shut-off cord (lanyard) to your PFD, arm, or leg so the engine stops if you accidentally leave the helm, which could prevent a runaway boat.

EMU33851

Other labels

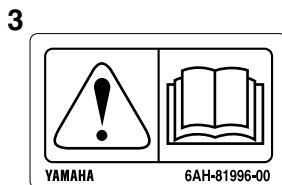

ZMU05710

ZMU06191

General information

EMU35133

Symbols

The following symbols mean as follows.

Notice/Warning



ZMU05696

Read Owner's Manual

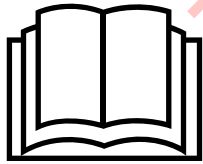

ZMU05664

Hazard caused by continuous rotation

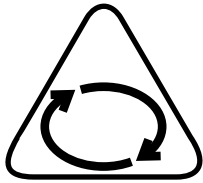

ZMU05665

Electrical hazard

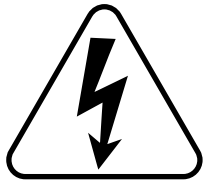

ZMU05666

Specifications and requirements

EMU34522

Specifications

TIP:

“(AL)” stated in the specification data below represents the numerical value for the aluminum propeller installed. Likewise, “(SUS)” represents the value for stainless steel propeller installed and “(PL)” for plastic propeller installed.

EMU2821V

Dimension and weight:

Overall length:
1029 mm (40.5 in)

Overall width:
633 mm (24.9 in)

Overall height X:
2006 mm (79.0 in)

Overall height U:
2133 mm (84.0 in)

Motor transom height X:
637 mm (25.1 in)

Motor transom height U:
764 mm (30.1 in)

Dry weight (SUS) X:
356 kg (785 lb)

Dry weight (SUS) U:
364 kg (802 lb)

Performance:

Full throttle operating range:
5000–6000 r/min

Rated power:
257.4 kW (350 HP)

Idle speed (in neutral):
600–700 r/min

Power unit:

Type:
4-stroke DOHC V8 32 valves

Total displacement:
5330 cm³ (325.2 c.i.)

Bore × stroke:
94.0 × 96.0 mm (3.70 × 3.78 in)

Ignition system:
TCI

Spark plug (NGK):
LFR6A-11

Spark plug gap:
1.0–1.1 mm (0.039–0.043 in)

Steering system:
Remote steering

Starting system:
Electric starter

Starting carburetion system:
Fuel injection

Valve clearance IN (cold engine):
0.17–0.24 mm (0.0067–0.0094 in)

Valve clearance EX (cold engine):
0.31–0.38 mm (0.0122–0.0150 in)

Battery rating (CCA/SAE):
700–1150 A

Battery rating (MCA/ABYC):
900–1370 A

Battery rating (RC/SAE):
170 minutes

Battery rating (CCA/EN):
670–1080 A

Battery rating (20HR/IEC):
110 Ah

Maximum generator output:
50 A

Lower unit:

Gear shift positions:
Forward-neutral-reverse

Gear ratio:
1.73 (26/15)

Trim and tilt system:
Power trim and tilt

Propeller mark:
X (F350CC)
XL (LF350CC)

Fuel and oil:

Recommended fuel:
Mid-grade unleaded gasoline (For North America),
Premium unleaded gasoline

Min. pump octane number (PON):
89

Min. research octane number (RON):
94

Recommended engine oil:
YAMALUBE 4M FC-W or 4-stroke outboard motor
oil

Recommended engine oil grade 1:
SAE 10W-30/10W-40/5W-30
API SE/SF/SG/SH/SJ/SL

Engine oil quantity (without oil filter replacement):
6.3 L (6.66 US qt, 5.54 Imp.qt)

Engine oil quantity (with oil filter replacement):
6.5 L (6.87 US qt, 5.72 Imp.qt)

Lubrication system:
Wet sump

Recommended gear oil:
Yamalube Marine Gearcase Lube HD or Hypoid
gear oil

Recommended gear oil grade:
SAE 80W API GL-5 / SAE 90 API GL-5

Gear oil quantity:
1.310 L (1.385 US qt, 1.153 Imp.qt) (LF350CC)
1.520 L (1.607 US qt, 1.338 Imp.qt) (F350CC)

Tightening torque:

Spark plug:
28 Nm (2.86 kgf-m, 20.7 ft-lb)

Propeller nut:
54 Nm (5.51 kgf-m, 39.8 ft-lb)

Engine oil drain bolt:
27 Nm (2.75 kgf-m, 19.9 ft-lb)

Engine oil filter:
18 Nm (1.84 kgf-m, 13.3 ft-lb)

Specifications and requirements

EMU33556

Installation requirements

EMU33565

Boat horsepower rating

EWM01561

⚠ WARNING

Overpowering a boat can cause severe instability.

Before installing the outboard motor(s), confirm that the total horsepower of your outboard motor(s) does not exceed the boat's maximum horsepower rating. See the boat's capacity plate or contact the manufacturer.

EMU33572

Mounting motor

EWM01571

⚠ WARNING

- **Improper mounting of the outboard motor could result in hazardous conditions such as poor handling, loss of control, or fire hazards.**
- **Because the motor is very heavy, special equipment and training is required to mount it safely.**

Your dealer or other person experienced in proper rigging should mount the motor using correct equipment and complete rigging instructions. For further information, see page 40.

EMU34954

Digital electronic control requirements

The digital electronic control is equipped with a start-in-gear protection device(s). This device prevents the engine from starting unless it is in neutral.

EWM01581

⚠ WARNING

- **If the engine starts in gear, the boat can move suddenly and unexpectedly, possibly causing a collision or throwing passengers overboard.**
- **If the engine ever starts in gear, the start-in-gear protection device is not working correctly and you should discontinue using the outboard. Contact your Yamaha dealer.**

This digital electronic control unit is only available for the outboard motor which you have purchased.

Prior to use of the digital electronic control unit, set it in order to operate your outboard motor only. Otherwise, it will not be possible to operate the outboard motor.

Perform setting of the outboard motor and the digital electronic control unit in the following cases.

- If a used outboard motor is installed
- If the digital electronic control unit is replaced
- If the ECM (Electronic control module) of the used outboard motor is replaced
- If the ECM (Electronic control module) of the digital electronic control unit is replaced

Consult your Yamaha dealer for setting.

EMU25695

Battery requirements

EMU44723

Battery specifications

Standard lead-acid, AGM, gel-cell, and maintenance-free

batteries are permitted. Use a fully charged battery that meets the following specifications. The battery is an important component necessary to obtain sure engine starting and to maintain engine performance.

The engine may not start if the battery voltage is too low.

For North America

It is necessary to meet only two of the three specifications (CCA, MCA, and RC) in one of the following combinations:

- CCA/SAE and RC
- MCA/ABYC and RC

Battery rating (CCA/SAE):

700–1150 A

Battery rating (MCA/ABYC):

900–1370 A

Battery rating (RC/SAE):

170 minutes

For Oceania

It is necessary to meet the following specifications.

Battery rating (CCA/EN):

670–1080 A

Battery rating (20HR/IEC):

110 Ah

ECM01063

NOTICE

- **Do not use a battery that does not meet the specified capacity. If a battery that does not meet specifications is used, the electric system could perform poorly or be overloaded, causing electric system damage.**
- **Do not use a battery which exceeds the maximum CCA rating. If the batteries are used in parallel circuit, use new batteries of the same type and make sure that the total battery rating never exceed the maximum CCA rating.**

EMU36293

Mounting battery

Mount the battery holder securely in a dry, well-ventilated, vibration-free location in the boat. **WARNING! Do not put flammable items, or loose heavy or metal objects in the same compartment as the battery. Fire, explosion or sparks could result.** [EWM01821]

Battery cable

The battery cable size and length are critical. Consult your Yamaha dealer about the battery cable size and length.

EMU36303

Multiple batteries

To connect multiple batteries, such as for multiple engine configurations or for an accessory battery, consult your Yamaha dealer about battery selection and correct wiring.

Battery isolator

Your outboard motor is capable of charging an accessory battery separate from the starting battery using an optional isolator lead. Contact your Yamaha dealer for installation of an optional isolator lead with over-current protection.

Specifications and requirements

EMU41603

Propeller selection

Next to selecting an outboard motor, selecting the right propeller is one of the most important purchasing decisions a boater can make. The type, size, and design of your propeller have a direct impact on acceleration, top speed, fuel economy, and even engine life. Yamaha designs and manufactures propellers for every Yamaha outboard motor and every application.

Your Yamaha dealer can help you select the right propeller for your boating needs. Select a propeller that will allow the engine to reach the middle or upper half of the operating range at full throttle with the maximum boatload. Generally, select a larger pitch propeller for a smaller operating load and a smaller pitch propeller for a heavier load. If you carry loads that vary widely, select the propeller that lets the engine run in the proper range for your maximum load but remember that you may need to reduce your throttle setting to stay within the recommended engine speed range when carrying lighter loads.

Yamaha recommends to use a propeller suitable for the "Shift Dampener System (SDS)". For further information, consult your Yamaha dealer.

To check the propeller, see page 68.

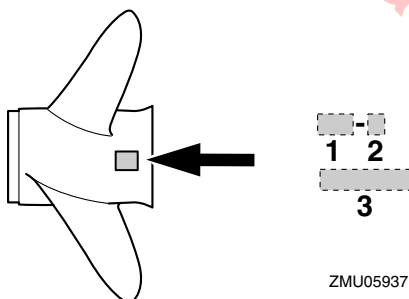

ZMU05937

1. Propeller pitch in inches
2. Type of propeller (propeller mark)
3. Propeller diameter in inches

EMU36313

Counter rotation models

Standard outboard motors rotate clockwise. Counter rotation models rotate counterclockwise and are typically used in multiple motor setups.

On counter rotation models, be sure to use a propeller intended for counterclockwise rotation. These propellers are identified with the letter "L" after the size indication on the propeller. **WARNING! Never use a standard propeller with a counter rotation motor, or a counter rotation propeller with a standard motor. Otherwise the boat could go in the direction opposite of that expected (for example, reverse instead of forward), which could lead to an accident.** [EWM01811]

For instructions on propeller removal and installation, see page 68.

EMU35141

Start-in-gear protection

Yamaha outboard motors or Yamaha-approved digital electronic control units are equipped with start-in-gear protection device(s). This feature permits the engine to be started only when it is in neutral. Always select neutral before starting the engine.

tion device(s). This feature permits the engine to be started only when it is in neutral. Always select neutral before starting the engine.

EMU41953

Engine oil requirements

Select an oil grade according to the average temperatures in the area where the outboard motor will be used.

Recommended engine oil:
YAMALUBE 4M FC-W or 4-stroke outboard motor oil

Recommended engine oil grade 1:
SAE 10W-30/10W-40/5W-30
API SE/SF/SG/SH/SJ/SL

Recommended engine oil grade 2:
SAE 15W-40/20W-40/20W-50
API SH/SJ/SL

Engine oil quantity (without oil filter replacement):
6.3 L (6.66 US qt, 5.54 Imp.qt)

Engine oil quantity (with oil filter replacement):
6.5 L (6.87 US qt, 5.72 Imp.qt)

If oil grades listed under Recommended engine oil grade 1 are not available, select an alternative oil grade listed under Recommended engine oil grade 2.

Recommended engine oil grade 1

SAE		API							
-4	14	32	50	68	86	104	122	F	
-20	-10	0	10	20	30	40	50	C	
									SE SF SG SH SJ SL

ZMU06854

Recommended engine oil grade 2

SAE		API							
-4	14	32	50	68	86	104	122	F	
-20	-10	0	10	20	30	40	50	C	
									SH SJ SL

ZMU06855

EMU36361

Fuel requirements

EMU44791

Gasoline

Use a good quality gasoline that meets the minimum octane requirement. If knocking or pinging occurs, use a different brand of gasoline or premium unleaded fuel. Yamaha recommends that you use alcohol-free gasoline (see Gasoline with Ethanol) whenever possible.

The use of a poor quality gasoline may result in starting and running problems. If you encounter drivability problems, which you suspect could be related to the fuel you are using,

Specifications and requirements

ing, Yamaha recommends that you switch to a recognized high quality brand of gasoline, such as a gasoline that is advertised as Top Tier Detergent Gasoline. (North America only) **NOTICE: Failure to comply with these recommendations may also result in unscheduled maintenance, fuel system damage, and internal engine damage.**

[ECM04480]

For North America

Recommended fuel:
Mid-grade unleaded gasoline
Min. pump octane number (PON):
89

For Oceania

Recommended fuel:
Premium unleaded gasoline
Min. research octane number (RON):
94

ECM01982

NOTICE

- **Do not use leaded gasoline. Leaded gasoline can seriously damage the engine.**
- **Avoid getting water and contaminants in the fuel tank. Contaminated fuel can cause poor performance or engine damage. Use only fresh gasoline that has been stored in clean containers.**

Gasoline with Ethanol

Two types of gasoline are commonly available in the U.S.A., Canada, Australia and New Zealand for use in automobiles and boats: conventional gasoline without Ethanol and gasoline with Ethanol, which is typically referred to as E10 gasoline. According to federal regulations, E10 gasoline may contain up to 10% Ethanol.

A high quality gasoline without Ethanol is the preferred fuel for your Yamaha outboard motor. However, if gasoline with Ethanol is the only fuel available in your area, your Yamaha outboard motor is calibrated to run properly on fresh E10 gasoline that meets the minimum octane requirement specified for this model.

ECM02402

NOTICE

Never use a gasoline for your outboard motor that contains more than 10% Ethanol, such as E15 which contains 15% Ethanol or E85 which contains 85% Ethanol, or gasoline containing any amount of Methanol. These fuels can cause starting and running problems, as well as serious fuel system and internal engine damage.

Gasoline containing ethanol has several properties that may cause boat fuel system problems.

- Ethanol is a strong solvent (cleaning agent) that can clean gum and varnish deposits from a boat's fuel system, particularly in older boats, as well as tanks and pipes used in gasoline distribution. These released deposits contaminate the fuel and can cause problems, such as clogged fuel filters, carburetors, or fuel injectors, which could result in engine damage.

- Ethanol may dissolve resins used in the construction of fiberglass fuel tanks. The dissolved resins contaminate the fuel and can cause problems, such as clogged fuel filters, carburetors, or fuel injectors, which could result in engine damage.
- Ethanol is hygroscopic (has a strong attraction to water). Therefore, any water that inadvertently enters the fuel system, including moisture that is absorbed from the air, will mix with the ethanol in the gasoline. If the amount of water is excessive, the ethanol and water mixture will separate from the gasoline in a layer at the bottom of the fuel tank. This ethanol and water mixture is very corrosive to aluminum fuel tanks and fuel system components.
- The usable life span of E10 gasoline may be shorter than the normal length of off-season boat storage, causing starting and running problems related to stale fuel.

For more information on using fuel containing ethanol, visit: <http://www.yamaha-motor.com>

Gasoline Filtration

Yamaha outboard motors are equipped with internal fuel filters. However, excessive water or debris entering your engine's fuel system could prematurely clog the internal filters, causing starting and running problems, fuel system damage, and internal engine damage. Therefore, it is recommended that an external 10-micron water-separating fuel filter be installed on your boat and serviced frequently. Consult your authorized Yamaha dealer for a 10-micron filter that meets your engine's requirements.

EMU41342

Gasoline Additives

Gasoline blends change to meet automobile emission regulations and economic conditions. Additives, added by gasoline distributors, necessary for proper automobile engine operation and durability, may not be sufficient for typical boat applications. Intake valve and combustion chamber deposits may accumulate in boat engines more rapidly than encountered in automotive use. In addition, gasoline used for boating will typically age longer between refills than gasoline used in automobiles, resulting in stale and unusable gasoline that may cause starting and running problems, fuel system damage, and internal engine damage.

Yamaha recommends the use of two Yamalube gasoline additives to reduce internal deposits and extend the storage life of gasoline. Continuous use of Yamalube Ring Free Fuel Additive Plus reduces harmful internal deposits. Yamalube Fuel Stabilizer & Conditioner Plus added to fresh gasoline will help protect the fuel system from varnishing while helping to keep the gasoline's octane level from decreasing excessively during storage. Other additives may also be available on the market that may have varying degrees of effectiveness. Consult your Yamaha dealer concerning what may work best for the locally available gasoline and environmental conditions.

EMU41354

Anti-fouling paint

A clean hull is required to maintain your boat's performance. Boats moored in the water should be protected from marine growth (barnacles, mussels, and marine plants). If ap-

Specifications and requirements

proved by regulations for your area, the bottom of the hull can be coated with an anti-fouling paint to inhibit marine growth.

Anti-fouling paints specifically formulated for use on aluminum may be applied to the outboard motor. The original Yamaha paint surface may be scuffed lightly before applying anti-fouling paint, but do not remove the original paint. Removal of the original paint will increase the rate of corrosion.

ECM04821

NOTICE

- **Anti-fouling paint for fiberglass and wood may contain materials, such as copper, graphite, and tin, that can cause corrosion if applied to aluminum boats and outboard motor components. Never apply these types of paint to your outboard motor because rapid corrosion damage could occur.**
- **Anti-fouling paint can increase drag (friction) between the boat and the water, and possibly affect performance. If the effects are too great, reducing propeller pitch may be necessary.**

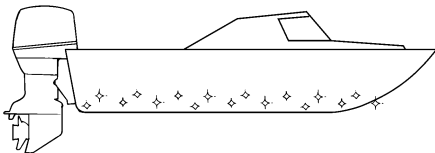

ZMU05176

Sacrificial anodes are attached to the outboard motor to provide corrosion protection and must never be painted. Sacrificial anodes made from a different material may be necessary for maximum corrosion protection due to your local water conditions. Please consult your Yamaha dealer.

ECM02421

NOTICE

Painted sacrificial anodes will not provide corrosion protection.

EMU40302

Outboard motor disposal requirements

Never illegally discard (dump) the outboard motor. Yamaha recommends consulting the dealer about discarding the outboard motor.

EMU36353

Emergency equipment

Keep the following items onboard in case there is trouble with the outboard motor.

- A tool kit with assorted screwdrivers, pliers, wrenches (including metric sizes), and electrical tape.
 - Waterproof flashlight with extra batteries.
 - An extra engine shut-off cord (lanyard) with clip.
 - Spare parts, such as an extra set of spark plugs.
- Consult your Yamaha dealer for details.

EMU25223

Emission control information

EMU25232

This engine conforms to U.S. Environmental Protection Agency (EPA) regulations for marine SI engines. See the label affixed to your engine for details.

EMU31563

Approval label of emission control certificate

This label is attached at the location shown.

New Technology; (4-stroke) MFI

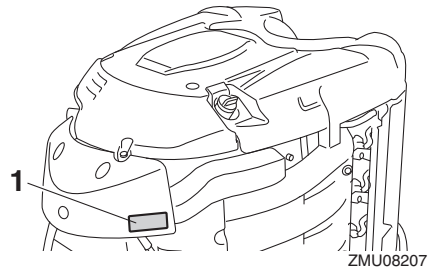

1. Approval label location

EMISSION CONTROL INFORMATION		MFI
THIS ENGINE CONFORMS TO CALIFORNIA AND U.S. EPA EXHAUST REGULATIONS FOR SI MARINE ENGINES. REFER TO THE OWNER'S MANUAL FOR MAINTENANCE SPECIFICATIONS AND ADJUSTMENTS. MEETS U.S. EPA EVAP STANDARDS USING CERTIFIED COMPONENTS.		
FAMILY:		MAX POWER: kW
FELs(HC+Nox/CO): g/kWhr		DISPLACEMENT: liters
IDLE SPEED: rpm IN NEUTRAL		FUEL: GASOLINE
SPARK PLUG: IN		SPARK PLUG GAP (mm)
VALVE LASH (mm)		EX:
YAMAHA MOTOR CO., LTD.		

ZMU06894

EMU25275

Star labels

Your outboard motor is labeled with a California Air Resources Board (CARB) star label. See below for a description of your particular label.

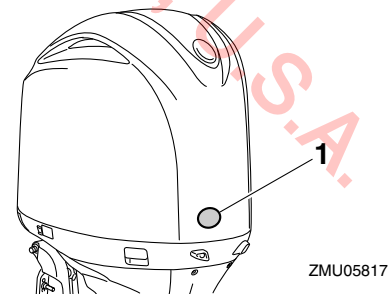

1. Star labels location

EMU40331

One Star—Low Emission

The one-star label identifies engines that meet the Air Resources Board's Personal Watercraft and Outboard marine engine 2001 exhaust emission standards. Engines meeting these standards have 75% lower emissions than conventional carbureted two-stroke engines. These engines are

Specifications and requirements

equivalent to the U.S. EPA's 2006 standards for marine engines.



ZMU01702



ZMU05663

EMU40341

Two Stars—Very Low Emission

The two-star label identifies engines that meet the Air Resources Board's Personal Watercraft and Outboard marine engine 2004 exhaust emission standards. Engines meeting these standards have 20% lower emissions than One Star-Low-Emission engines.



ZMU01703

EMU40351

Three Stars—Ultra Low Emission

The three-star label identifies engines that meet the Air Resources Board's Personal Watercraft and Outboard marine engine 2008 exhaust emission standards or the Sterndrive and Inboard marine engine 2003-2008 exhaust emission standards. Engines meeting these standards have 65% lower emissions than One Star-Low-Emission engines.



ZMU01704

EMU33862

Four Stars—Super Ultra Low Emission

The four-star label identifies engines that meet the Air Resources Board's Sterndrive and Inboard marine engine 2009 exhaust emission standards. Personal Watercraft and Outboard marine engines may also comply with these standards. Engines meeting these standards have 90% lower emissions than One Star-Low-Emission engines.

EMU46721

Components diagram

TIP:

* May not be exactly as shown; also may not be included as standard equipment on all models (order from dealer).

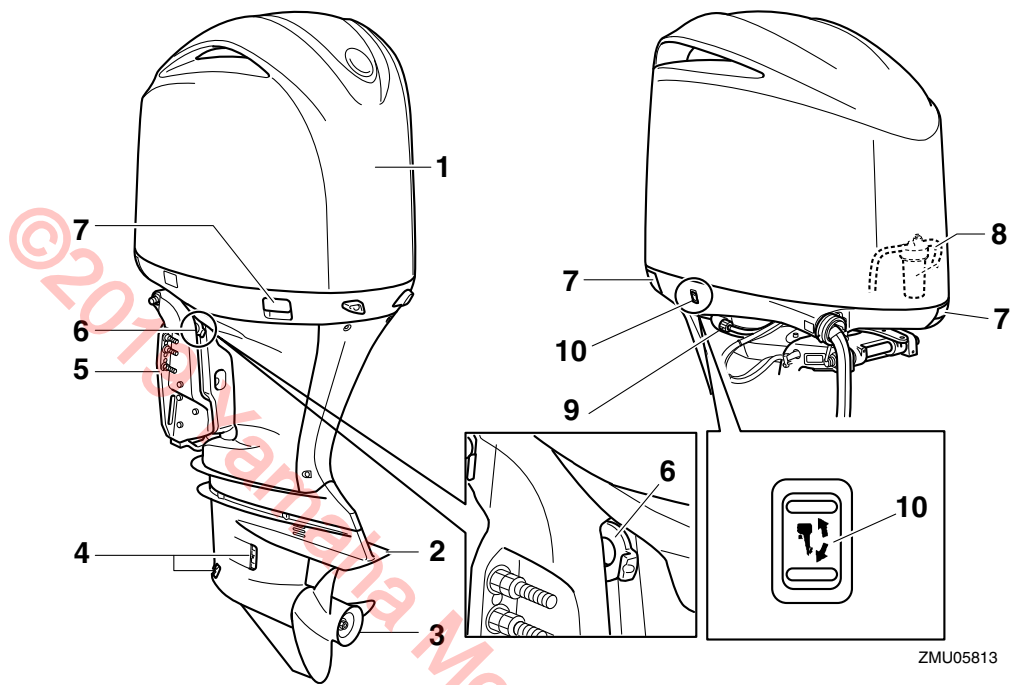

1. Top cowling
2. Anti-cavitation plate
3. Propeller*
4. Cooling water inlet
5. Clamp bracket
6. Tilt support lever
7. Cowling lock lever(s)
8. Fuel filter/water separator
9. Flushing device
10. Power trim and tilt switch

Components

EMU46731

Optional items

The following items are available from your Yamaha dealer. For details, consult your Yamaha dealer.

single type

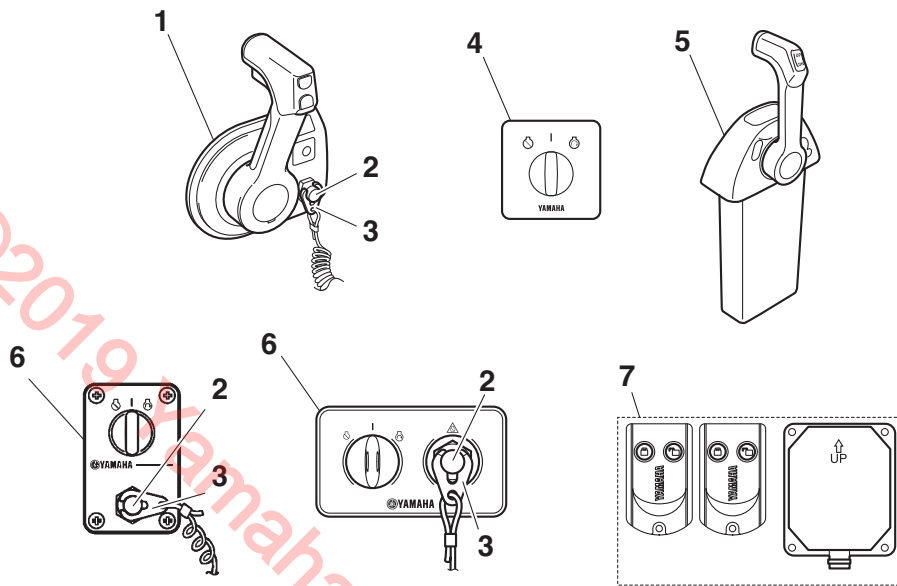

ZMU08567

1. Digital electronic control (side-mount type)
2. Engine shut-off switch
3. Clip
4. Switch panel (for use with side-mount type)

5. Digital electronic control (single type)
6. Switch panel (for use with single type)
7. Yamaha Security System (Y-COP)

twin/triple type

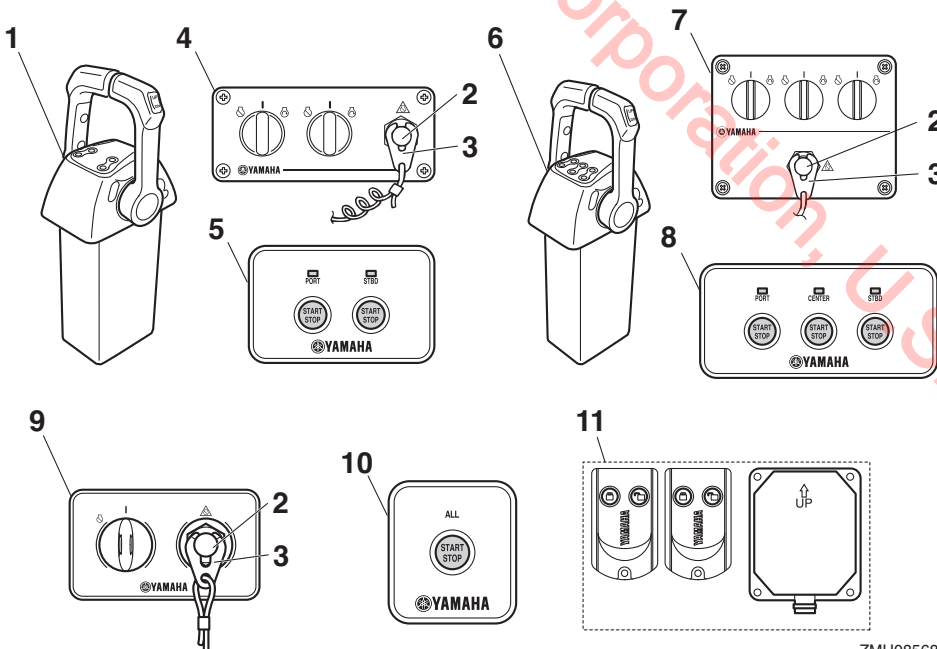

ZMU08568

1. Digital electronic control (twin type)
2. Engine shut-off switch
3. Clip
4. Switch panel (for use with twin type)

5. Start/Stop switch panel (for use with twin type)
6. Digital electronic control (triple type)
7. Switch panel (for use with triple type)
8. Start/Stop switch panel (for use with triple type)

- 9. Switch panel (for use with twin/triple type)
- 10. All Start/Stop switch panel (for use with twin/triple type)
- 11. Yamaha Security System (Y-COP)

meters

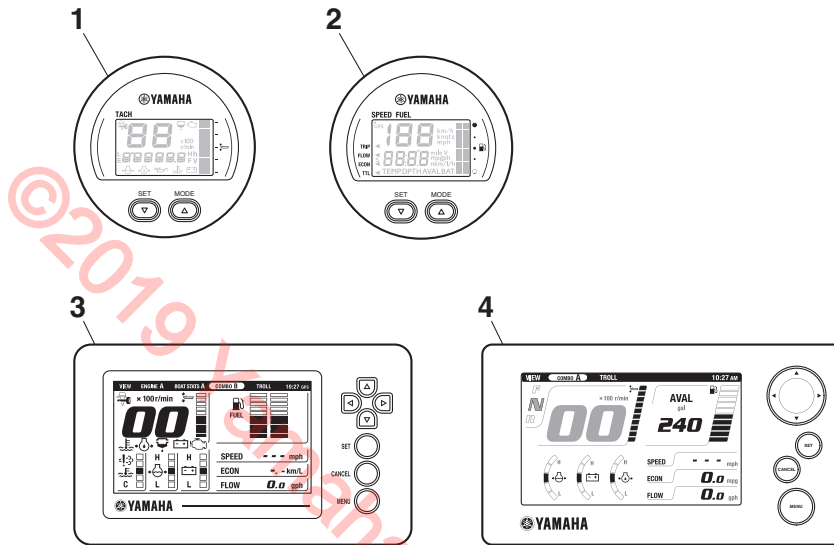

- 1. 6Y8 Multifunction tachometer
- 2. 6Y8 Multifunction speed & fuel meter
- 3. 6YC Multifunction meter
- 4. 6Y9 Multifunction Color Gauge

ZMU07670

Components

EMU46750

Yamaha Security System (Y-COP)

ECM02461

NOTICE

The Yamaha Security System is sold in conformity with the relevant laws and regulations regarding radio wave transmission. Therefore, if this product is used outside the country where it was sold, it may violate the laws or regulations regarding radio wave transmission in the country it is used in. For details, consult your Yamaha dealer.

The Yamaha Security System, which protects against theft, consists of the receiver and remote control transmitters. The Yamaha Security System is available from your Yamaha dealer. For details, consult your Yamaha dealer.

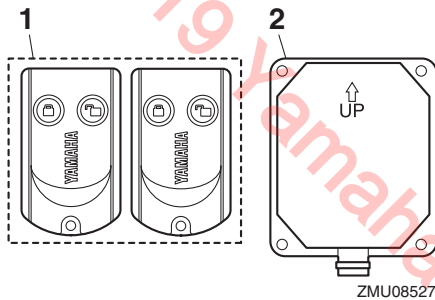

1. Remote control transmitter
2. Receiver

The engine cannot be started if the security system is in the lock mode. The engine can be started only in the unlock mode. For more information, see the installation and owner's manual included with the security system.

EMU35944

Digital electronic control

The digital electronic control actuates the shifter, the throttle and remote electrical operations. Make sure that the active indicator lights and that the digital electronic control unit is correctly connected to the outboard motor.

The digital electronic controls of the main station and sub station have the same functions.

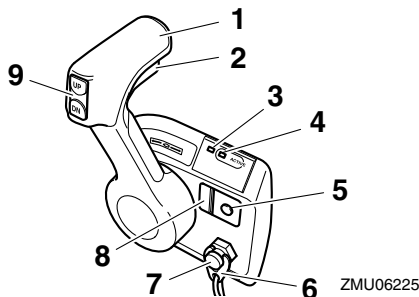

1. Control lever
2. Neutral interlock trigger
3. Digital electronic control-alert indicator
4. Digital electronic control-active indicator
5. Free throttle switch
6. Clip
7. Engine shut-off switch
8. Throttle friction adjuster

9. Power trim and tilt switch

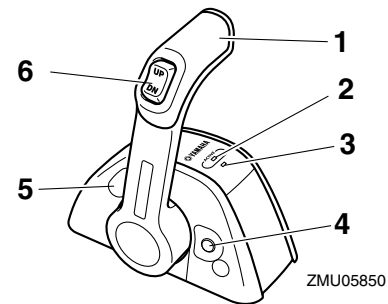

ZMU05850

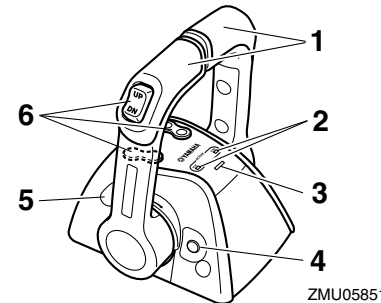

ZMU05851

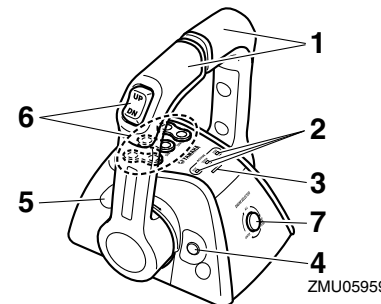

ZMU05959

1. Control lever
2. Digital electronic control-active indicator
3. Digital electronic control-alert indicator
4. Free throttle switch
5. Throttle friction adjuster
6. Power trim and tilt switch
7. Engine selector switch

EMU34974

Digital electronic control-active indicator

The digital electronic control-active indicator indicates that the digital electronic control system is in the operating state.

- **Lights:** Operation of both shift and throttle possible.
- **Blinks (when the gear shift is in neutral):** Shift not operable. Only throttle operation available.
- **Off:** Shift and throttle not operable.

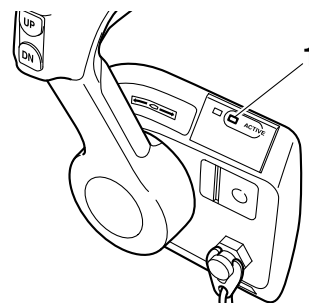

ZMU06276

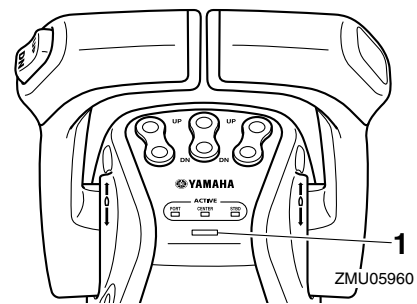
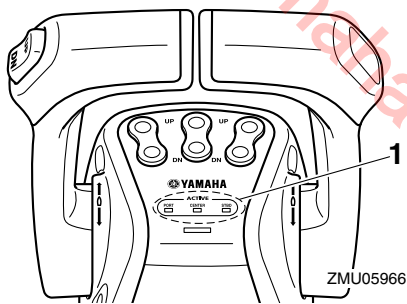
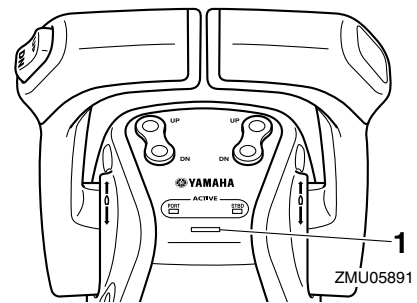
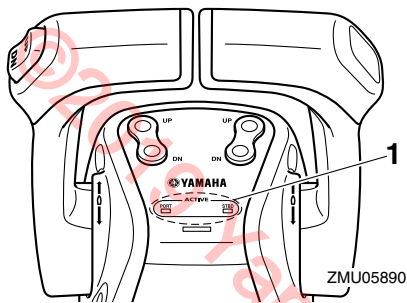
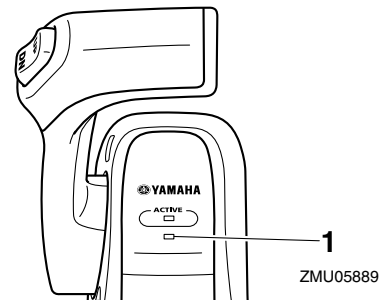
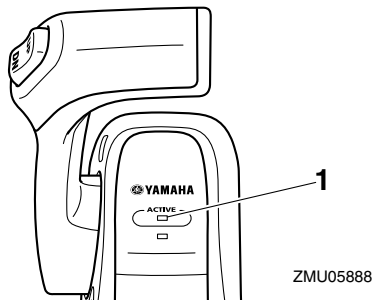

1. Digital electronic control-active indicator

1. Digital electronic control-alert indicator

EMU34985

Digital electronic control-alert indicator

The digital electronic control-alert indicator lights when trouble occurs in the connection between the digital electronic control and outboard motor. Consult your Yamaha dealer for details.

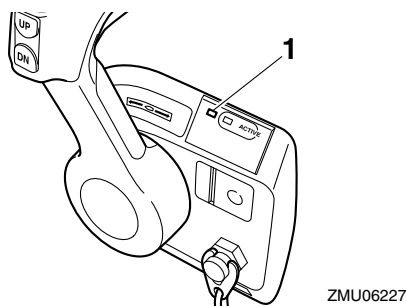

EMU35823

Control lever

Moving the lever forward from the neutral position engages forward gear. Pulling the lever back from neutral engages reverse. The engine will continue to run at idle until the lever is moved 22.5° (a detent can be felt). Moving the lever farther opens the throttle, and the engine will begin to accelerate.

Digital electronic control for twin type has the function to automatically synchronize both engine speeds.

Also digital electronic control for triple type has the function to automatically synchronize the engine speeds of the center engine and starboard side engine, adapting the port side engine speed.

The functions of the control lever for triple-type digital electronic control are as follows.

- Operate the port side engine using the port side control lever.
- The center engine runs at the average speed of port side and starboard side engines' speeds.
- Operate the starboard side engine using the starboard side control lever.

Components

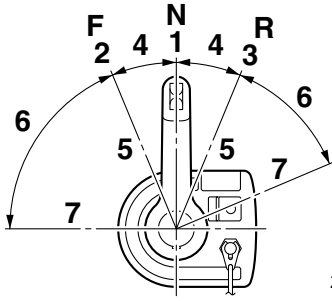

ZMU06228

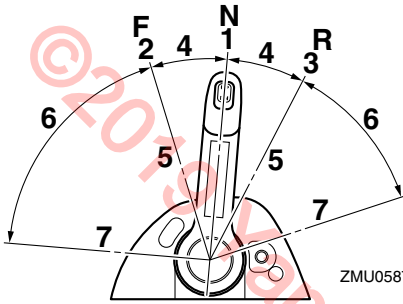

ZMU05878

1. Neutral "N"
2. Forward "F"
3. Reverse "R"
4. Shift
5. Fully closed
6. Throttle
7. Fully open

EMU26202

Neutral interlock trigger

To shift out of neutral, first pull the neutral interlock trigger up.

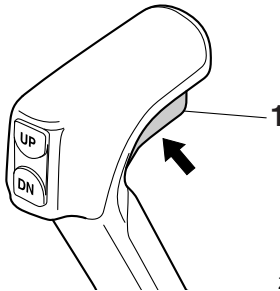

ZMU06285

1. Neutral interlock trigger

EMU35833

Free throttle switch

In neutral, keep this switch pressed, move the control lever forward, and release the switch after the digital electronic control-active indicator starts blinking. While the indicator blinks, you can open or close the throttle. This can also be done when the control lever is set in reverse.

Single type

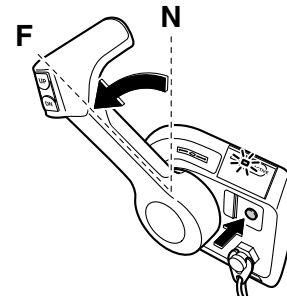

ZMU06231

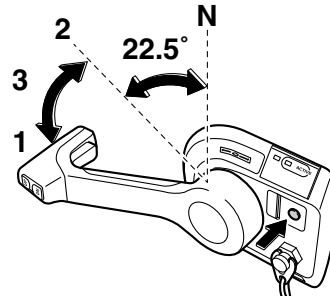

ZMU06232

1. Fully open
2. Fully closed
3. Free accelerator

Single type

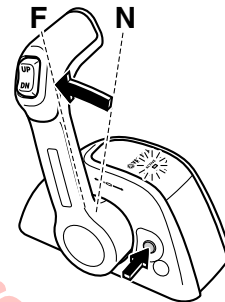

ZMU05880

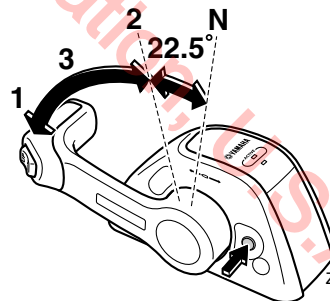

ZMU05881

1. Fully open
2. Fully closed
3. Free accelerator

Twin type

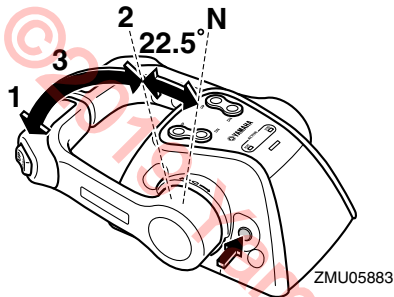
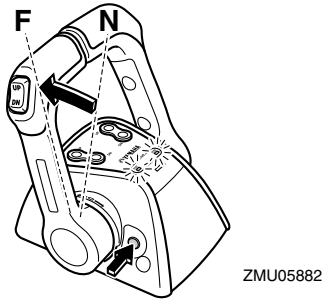

1. Fully open
2. Fully closed
3. Free accelerator

Triple type

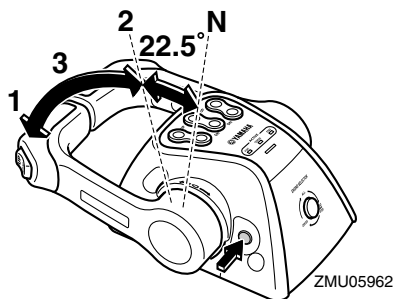
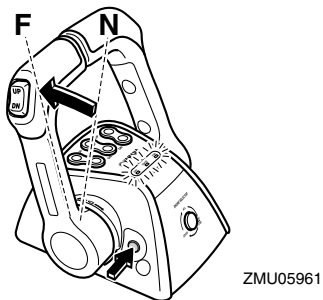

1. Fully open
2. Fully closed
3. Free accelerator

The free throttle switch can only be used when the control lever is in the neutral position.

During operation the digital electronic control-active indicator changes from continuously lit to blinking. When the indicator starts blinking, the throttle begins to open after the control lever is moved at least 22.5°.

After using the free throttle switch, return the control lever to the neutral position. The free throttle switch will return auto-

matically to its set position. The digital electronic control-active indicator will change from blinking to continuously lit and the digital electronic control will then engage forward and reverse normally.

EMU35873

Throttle friction adjuster

A friction device provides adjustable resistance to movement of the control lever, and can be set according to operator preference.

To increase resistance, turn the adjuster clockwise. To decrease resistance, turn the adjuster counterclockwise.

EWM01771

⚠ WARNING

- If the friction is too small, the control lever could move freely and cause an accident.
- Do not overtighten the friction adjuster. If there is too much resistance, it could be difficult to move the control lever, which could result in an accident.

Single type

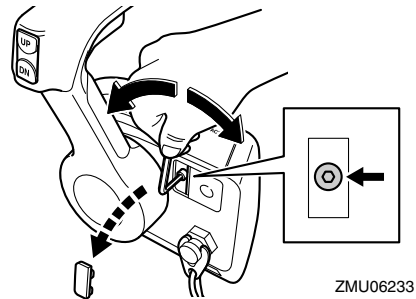

Single type

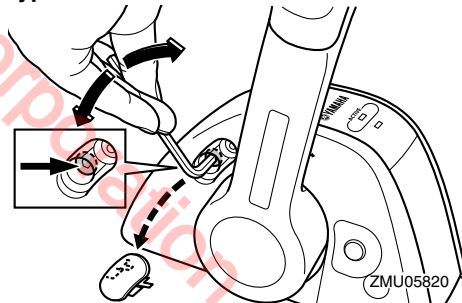

Twin type

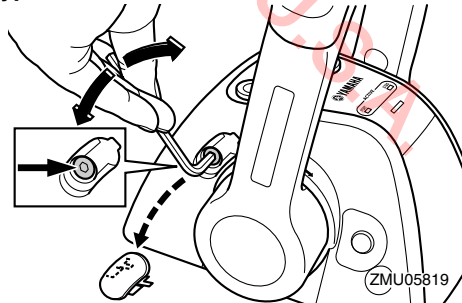

Components

Triple type

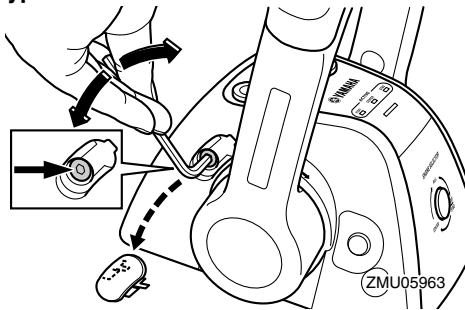

When constant speed is desired, tighten the adjuster to maintain the desired throttle setting.

EMU35721

Engine selector switch

When all engines have started, you can select the desired engine for operation by pushing the engine selector switch. The engine selector switch works only when all the control levers are in neutral.

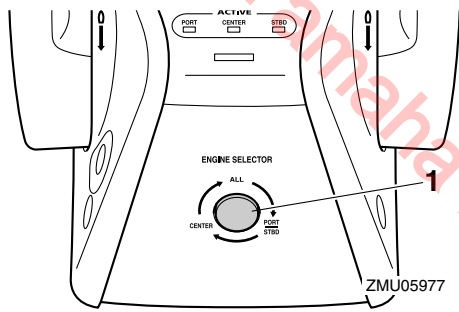

1. Engine selector switch

EMU35775

Engine shut-off cord (lanyard) and clip

The clip must be attached to the engine shut-off switch for the engine to run. The cord should be attached to a secure place on the operator's clothing, or arm or leg. Should the operator fall overboard or leave the helm, the cord will pull out the clip, stopping ignition to the engine. This will prevent the boat from running away under power.

EWMO1791

WARNING

- Attach the engine shut-off cord to a secure place on your clothing, or your arm or leg while operating.
- Do not attach the cord to clothing that could tear loose. Do not route the cord where it could become entangled, preventing it from functioning.
- Avoid accidentally pulling the cord during normal operation. Loss of engine power means the loss of most steering control. Also, without engine power, the boat could slow rapidly. This could cause people and objects in the boat to be thrown forward.

TIP:

The engine cannot be started with the clip removed.

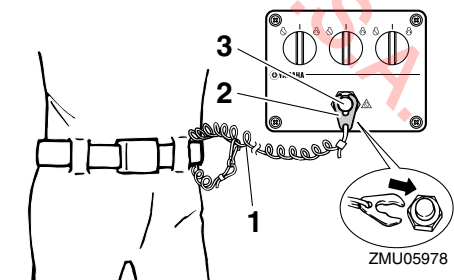
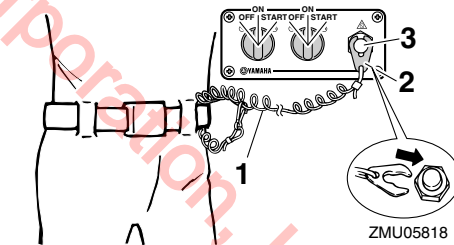
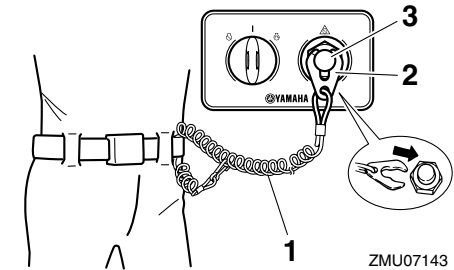
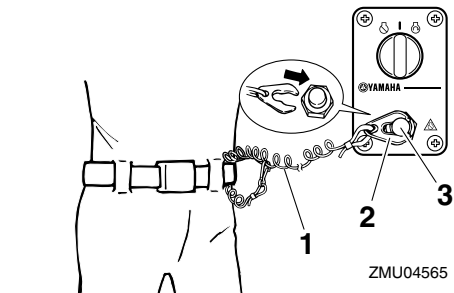
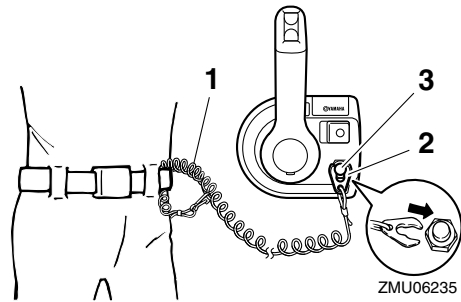

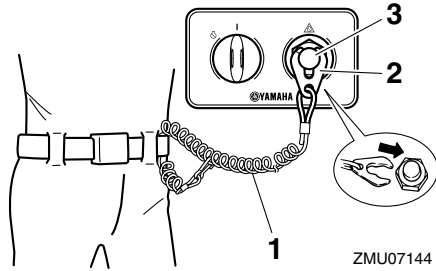

1. Cord
2. Clip
3. Engine shut-off switch

ZMU07144

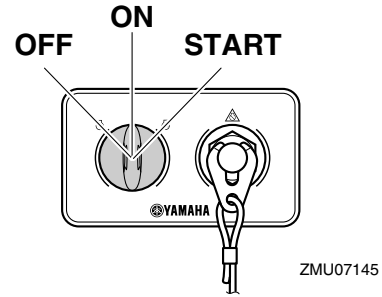

ZMU07145

Twin type

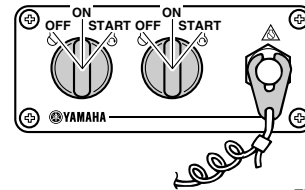

ZMU05821

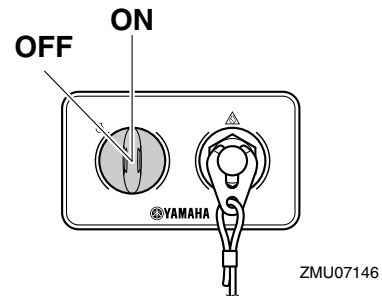

ZMU07146

Triple type

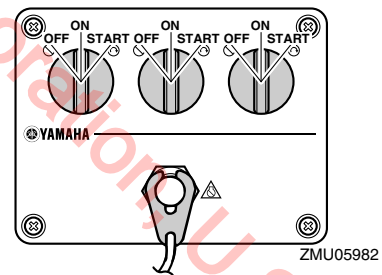

ZMU05982

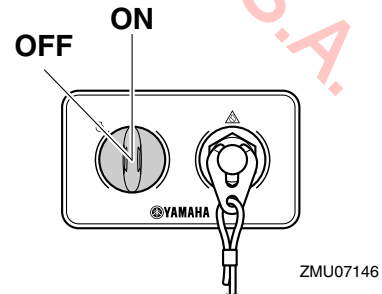

ZMU07146

EMU42081

Start/Stop switch panel

The engine can be started or turned off by pressing the Start/Stop button. For twin and triple type, it is possible to start or turn off individual engine. The indicator for the corresponding engine will come on.

Components

- **PORT:**Port side engine
- **CENTER:**Center engine
- **STBD:**Starboard side engine

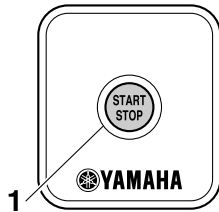

ZMU07173

1. Start/Stop button

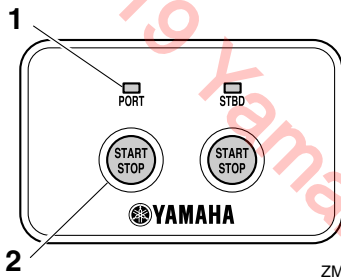

ZMU07174

1. Indicator
2. Start/Stop button

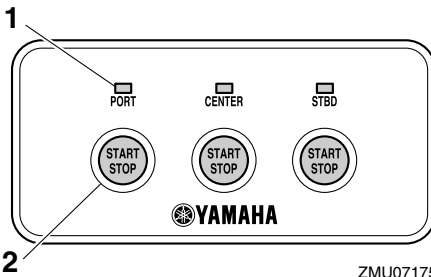

ZMU07175

1. Indicator
2. Start/Stop button

EMU41632

All Start/Stop switch panel

The Start/Stop button allows all engines to start or turn off.

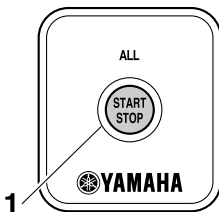

ZMU07176

1. All Start/Stop button

EMU35154

Power trim and tilt switch on digital electronic control

The power trim and tilt system adjusts the outboard motor angle in relation to the transom. Pressing the switch “UP” (up) trims the outboard motor up, and then tilts it up. Pressing the switch “DN” (down) tilts the outboard motor down and trims it down. When the switch is released, the outboard motor will stop in its current position. For instructions on using the power trim and tilt switch, see pages 56 and 57.

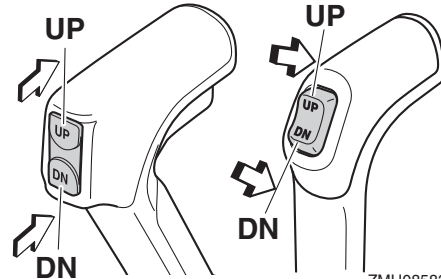

ZMU08583

EMU26156

Power trim and tilt switch on bottom cowling

The power trim and tilt switch is located on the side of the bottom cowling. Pushing the switch “UP” (up) trims the outboard motor up, and then tilts it up. Pushing the switch “DN” (down) tilts the outboard motor down and trims it down. When the switch is released, the outboard motor will stop in its current position.

For instructions on using the power trim and tilt switch, see page 57.

EWM01032

WARNING

Use the power trim and tilt switch located on the bottom cowling only when the boat is at a complete stop with the engine off. Attempting to use this switch while the boat is moving could increase the risk of falling overboard and could distract the operator, increasing the risk of collision with another boat or an obstacle.

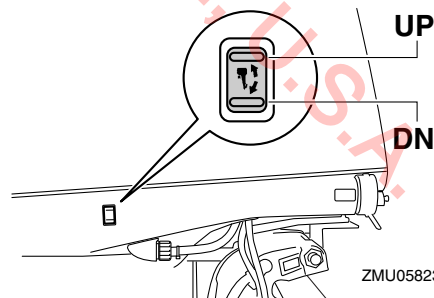

ZMU05823

EMU42261

Power trim and tilt switches

The power trim and tilt system adjusts the outboard motor angle in relation to the transom. Pushing the switch “UP” (up) trims the outboard motor up, and then tilts it up. Pressing the switch “DN” (down) tilts the outboard motor down and trims it down. When the switch is released, the outboard motor will stop in its current position.

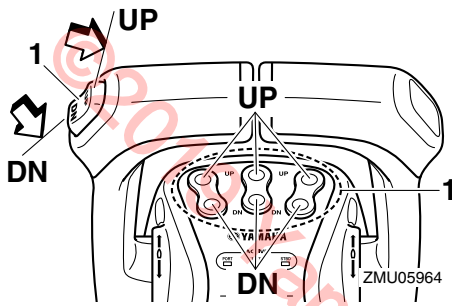
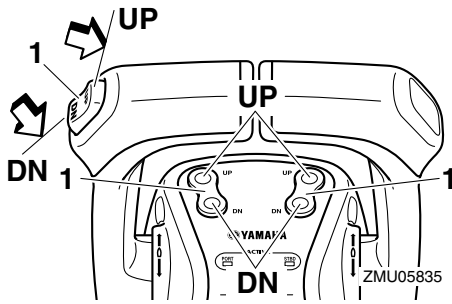

1. Power trim and tilt switch

The switch on the control grip controls all outboard motors at the same time.

For instructions on using the power trim and tilt switches, see pages 56 and 57.

EMU35041

Tilt limiter

This outboard motor is equipped with a tilt limiter that controls the tilt range.

TIP:

Consult your Yamaha dealer about changing the setting.

EMU35031

Tilt support lever for power trim and tilt model

To keep the outboard motor in the tilted up position, lock the tilt support lever to the clamp bracket. Make sure that the lever is securely retained by the bolts.

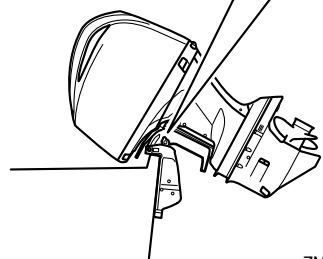
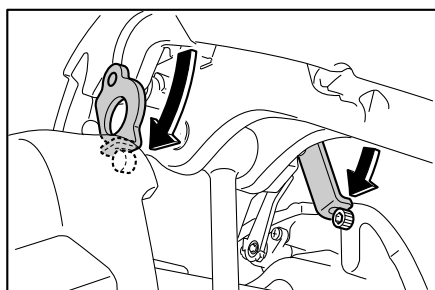

ZMU05824

ECM00661

NOTICE

Do not use the tilt support lever or knob when trailering the boat. The outboard motor could shake loose from the tilt support and fall. If the motor cannot be trailered in the normal running position, use an additional support device to secure it in the tilt position.

EMU40762

Cowling lock lever

The cowling lock levers are used to secure the top cowling.

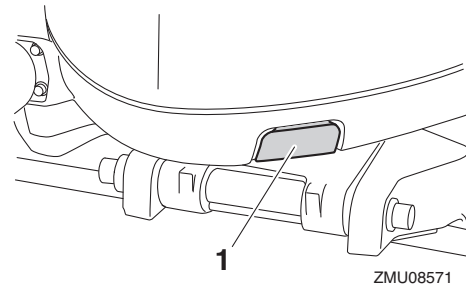

1. Cowling lock lever

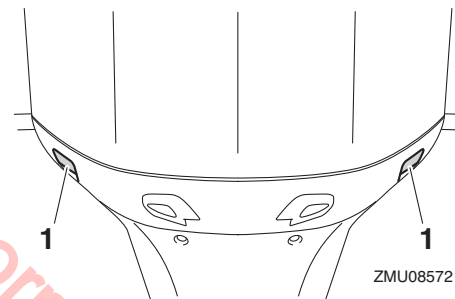

1. Cowling lock lever(s)

EMU26464

Flushing device

This device is used to clean the cooling water passages of the motor using a garden hose and tap water.

Components

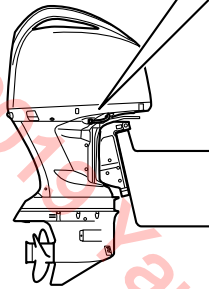
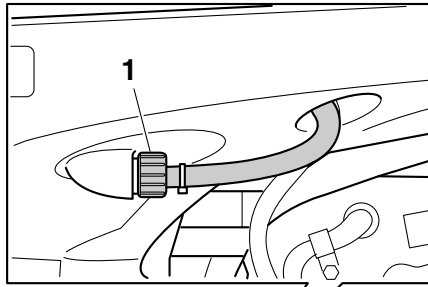

ZMU05825

1. Flushing device

TIP:

For details on usage, see page 62.

EMU40823

Fuel filter

The fuel filter functions to remove foreign material and separate water from the fuel. If water separated from the fuel exceeds a specific volume, the alert system will activate. For further information, see page 39.

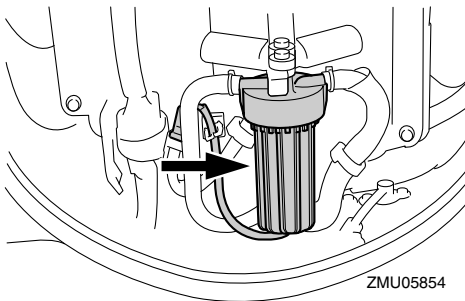

ZMU05854

TIP:

Adding an in-line 10-micron fuel filter has been shown to greatly reduce the chance of fuel contamination problems. Consult your dealer for information about Yamaha 10-micron fuel filters if your boat does not have one.

Instruments and indicators

EMU41782

6Y9 Multifunction Color Gauge

The 6Y9 Multifunction Color Gauge (hereinafter called the Multi-Display) shows engine status and alert information. The display of optional items can be changed. This manual mainly covers the alert display. For information on other settings or changing the display, see the 6Y9 Multifunction Color Gauge owner's manual.

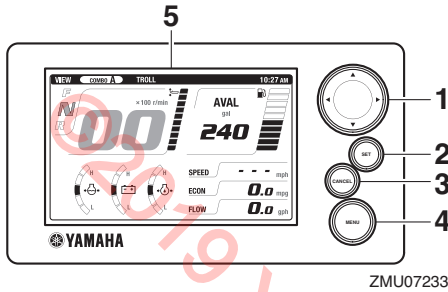

ZMU07233

1. Arrow keys
2. Set button
3. Cancel button
4. Menu button
5. Display

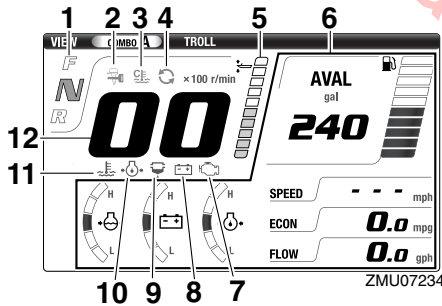

ZMU07234

1. Shift position display
2. Yamaha Security System indicator (optional)
3. Engine warm-up indicator
4. Engine synchronization indicator
5. Trim meter
6. Optional items
7. Engine trouble-alert indicator
8. Low battery voltage-alert indicator
9. Water separator-alert indicator
10. Low oil pressure-alert indicator
11. Overheat-alert indicator
12. Tachometer

EMU41643

Yamaha Security System indicator (optional)

This indicator appears when the Yamaha Security System is in lock mode. Make sure it is off before starting the engine.

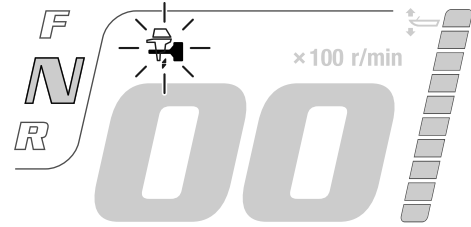

ZMU07235

EMU41651

Engine warm-up indicator

This indicator appears while the engine is being warmed up and goes off when warming-up is finished.

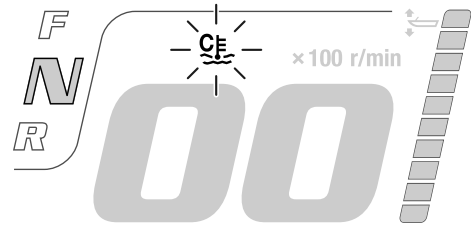

ZMU07236

EMU42302

Engine synchronization indicator

In twin and triple types, this indicator appears while the engines are under engine synchronization control. It goes off when engine synchronization control is released. For quad type, this indicator does not appear.

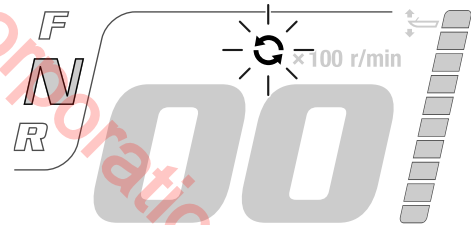

ZMU07237

EMU41682

Overheat alert

If the engine temperature rises too high while cruising, the pop-up window will appear. Press the "set" (set) button to change to normal display, and the overheat-alert indicator will start to blink. The engine speed will automatically decrease to about 2000 r/min.

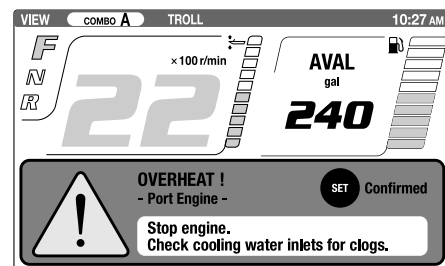

ZMU07238

Instruments and indicators

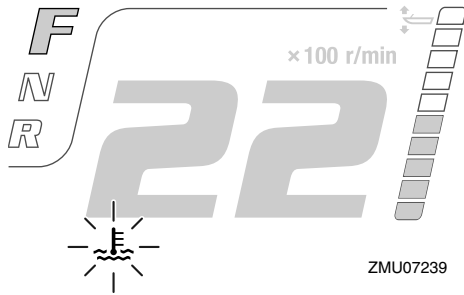

Stop the engine immediately if the buzzer sounds and the overheat alert device has activated. Check the cooling water inlet for clogging.

ECM01594

NOTICE

- Do not continue to run the engine if the overheat-alert indicator blinks. Serious engine damage will occur.
- Do not continue to operate the engine if an alert device has activated. Consult your Yamaha dealer if the problem cannot be located and corrected.

EMU41691

Low oil pressure-alert

If the engine oil pressure drops too low, the pop-up window will appear. Press the “set” (set) button to change to normal display, and the low oil pressure-alert indicator will start to blink. The engine speed will automatically decrease to about 2000 r/min.

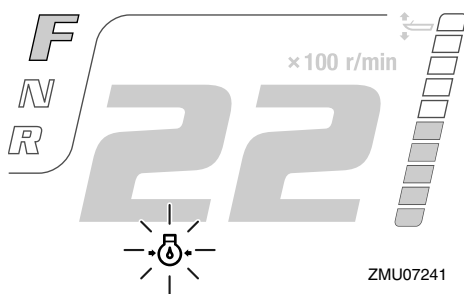
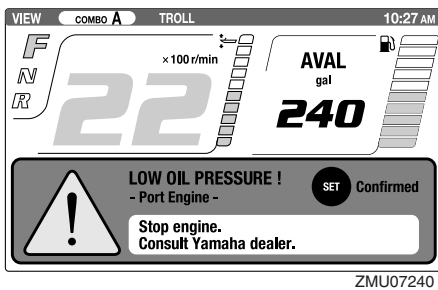

Stop the engine immediately if the buzzer sounds and the low oil pressure-alert device has activated. Check the engine oil quantity and replenish oil if necessary. If the alert device has activated while the appropriate engine oil quantity is maintained, consult your Yamaha dealer.

ECM01602

NOTICE

Do not continue to run the engine if the low oil pressure alert device has activated. Serious engine damage will occur.

EMU41701

Water separator alert

The pop-up window will appear if water has accumulated in the water separator (fuel filter) while cruising. Press the “set” (set) button to change to normal display, and the water separator-alert indicator will start to blink.

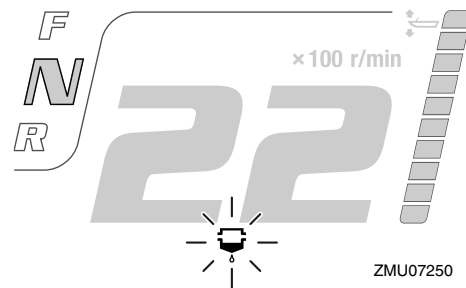
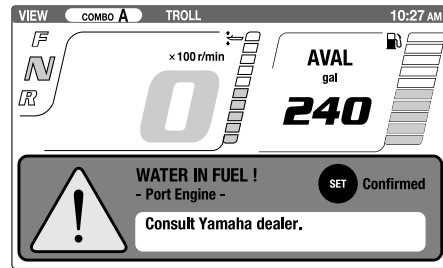

Stop the engine immediately and see page 75 of this manual to drain the water from the fuel filter. Get back to the port soon and consult a Yamaha dealer immediately.

ECM00911

NOTICE

Gasoline mixed with water could cause damage to the engine.

EMU41721

Low battery voltage-alert

The pop-up window will be displayed if the battery voltage drops. Press the “set” (set) button will change to the normal display and the battery voltage-alert indicator will start to blink.

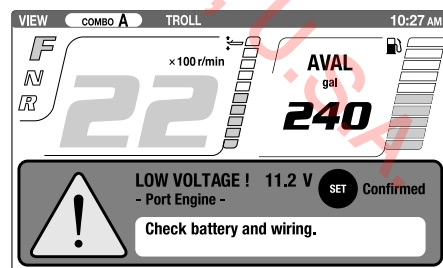

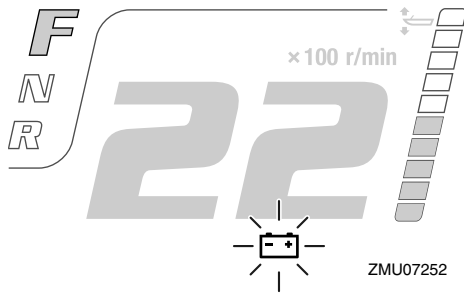

ZMU07252

Get back to the port soon if the low battery voltage-alert device has activated. For charging the battery, consult your Yamaha dealer.

EMU41711

Engine trouble alert

The pop-up window will appear if the engine malfunctions while cruising. Press the “set” (set) button to change to normal display, and the engine trouble-alert indicator will start to blink.

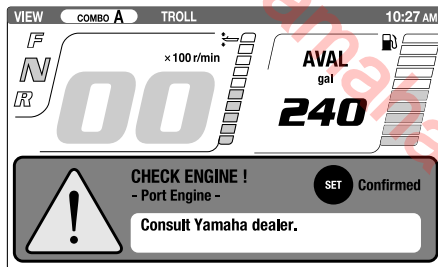

ZMU07253

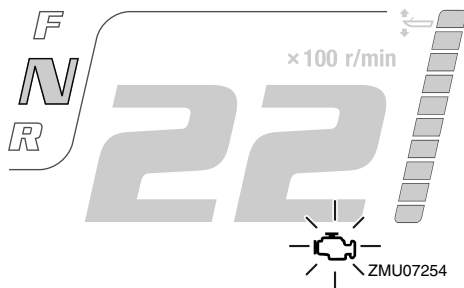

ZMU07254

Return to port and consult a Yamaha dealer immediately.

EMU46661

6YC Multifunction meter

The 6YC Multifunction meter shows engine status and alert information.

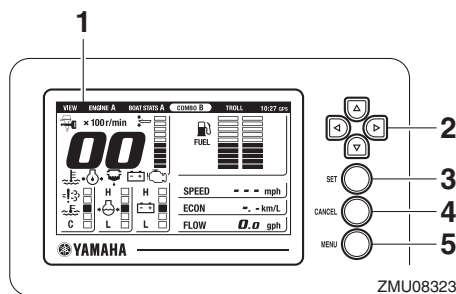

ZMU08323

1. Multifunction display
2. Directional keypad
3. Set button

4. Cancel button
5. Menu button

Multifunction display

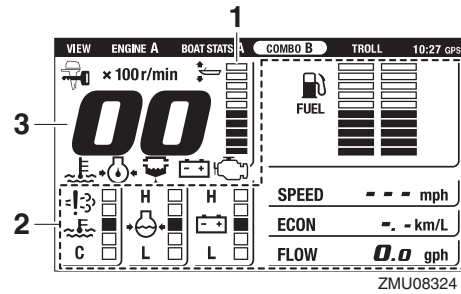

ZMU08324

1. Trim meter
2. Optional items
3. Tachometer

TIP:

The optional items displayed on the multifunction display can be changed. For information on other settings or changing the displayed optional items, see the operation manual included with the 6YC Multifunction meter.

This manual mainly covers the alert display of the 6YC Multifunction meter. See the following sections for information about the display and indicators.

Indicators

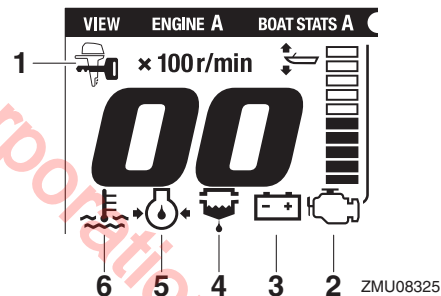

ZMU08325

1. Yamaha Security System indicator (optional)
2. Engine trouble-alert indicator
3. Low battery voltage-alert indicator
4. Water separator-alert indicator
5. Low oil pressure-alert indicator
6. Overheat-alert indicator

Yamaha Security System indicator (optional)

This indicator appears, when the Yamaha Security System is in lock mode.

Instruments and indicators

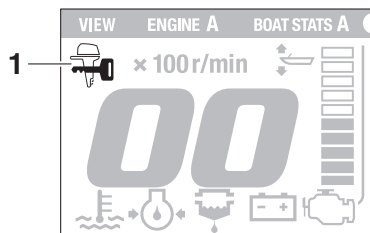

ZMU08326

1. Yamaha Security System indicator (optional)

Make sure that the Yamaha Security System indicator is off before starting the engine.

Engine trouble alert

If the engine malfunctions while cruising, the pop-up window will appear.

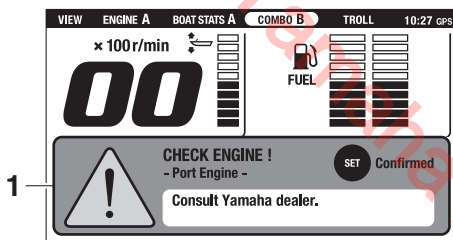

ZMU08327

1. Pop-up window

To return to the normal display

Push the “SET” (set) button, and the engine trouble-alert indicator will start to blink.

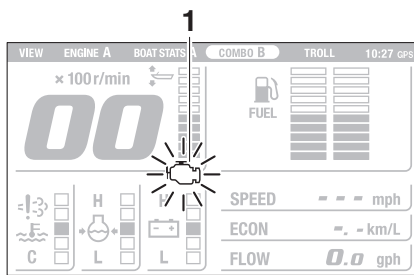

ZMU08332

1. Engine trouble-alert indicator

ECM00921

NOTICE

In such an event, the engine will not operate properly. Consult a Yamaha dealer immediately.

Low battery voltage alert

If the battery voltage drops, the pop-up window will appear.

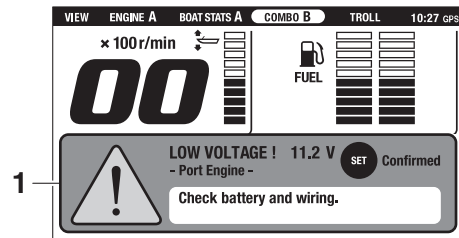

ZMU08328

1. Pop-up window

To return to the normal display

Push the “SET” (set) button, and the low battery voltage-alert indicator will start to blink.

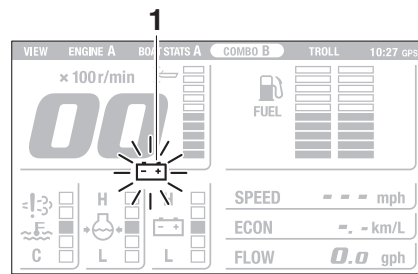

ZMU08333

1. Low battery voltage-alert indicator

Get back to the port soon if the low battery voltage-alert device has activated. For charging the battery, consult your Yamaha dealer.

Water separator alert

If water has accumulated in the water separator (fuel filter) while cruising, the pop-up window will appear.

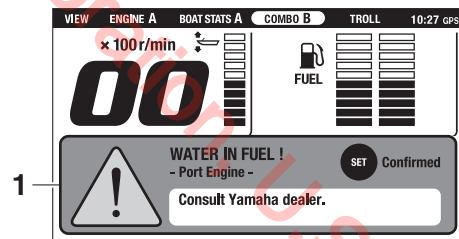

ZMU08329

1. Pop-up window

To return to the normal display

Push the “SET” (set) button, and the water separator-alert indicator will start to blink.

Instruments and indicators

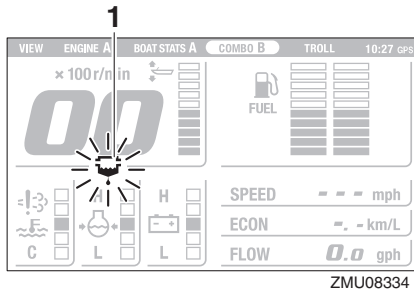

1. Water separator-alert indicator

Stop the engine immediately and see page 75 of this manual to drain the water from the fuel filter. Get back to the port soon and consult a Yamaha dealer immediately.

ECM00911

NOTICE

Gasoline mixed with water could cause damage to the engine.

Low oil pressure alert

If the engine oil pressure drops too low, the pop-up window will appear.

The engine speed will automatically decrease to about 2000 r/min.

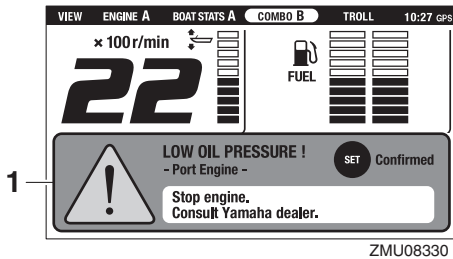

1. Pop-up window

To return to the normal display

Push the “SET” (set) button, and the low oil pressure-alert indicator will start to blink.

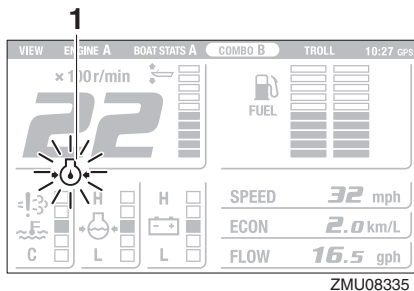

1. Low oil pressure-alert indicator

Stop the engine immediately if the buzzer sounds and the low oil pressure-alert device is activated. Check the engine oil quantity and replenish oil if necessary. If the alert device has activated while the appropriate engine oil quantity is maintained, consult your Yamaha dealer.

ECM01602

NOTICE

Do not continue to run the engine if the low oil pressure alert device has activated. Serious engine damage will occur.

Overheat alert

If the engine temperature rises too high while cruising, the pop-up window will appear.

The engine speed will automatically decrease to about 2000 r/min.

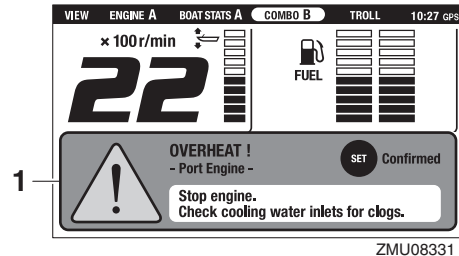

1. Pop-up window

To return to the normal display

Push the “SET” (set) button, and the overheat-alert indicator will start to blink.

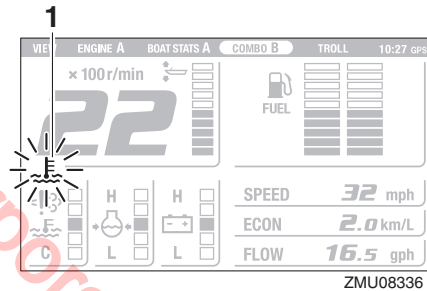

1. Overheat-alert indicator

Stop the engine immediately if the buzzer sounds and the overheat device has activated. Check the cooling water inlet for clogging.

ECM01594

NOTICE

- Do not continue to run the engine if the overheat-alert indicator blinks. Serious engine damage will occur.
- Do not continue to operate the engine if an alert device has activated. Consult your Yamaha dealer if the problem cannot be located and corrected.

EMU46651

6Y8 Multifunction meters

There are two types of 6Y8 Multifunction meters.

- 6Y8 Multifunction tachometer
- 6Y8 Multifunction speed & fuel meter

Instruments and indicators

6Y8 Multifunction tachometer

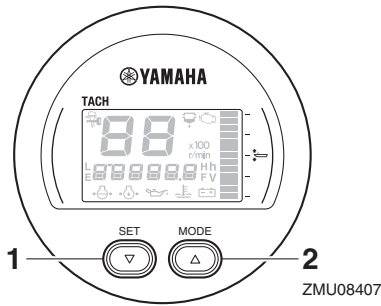

1. Set button
2. Mode button

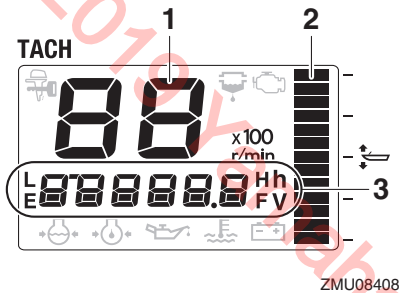

1. Tachometer
2. Trim meter
3. Multifunction display

6Y8 Multifunction speed & fuel meter

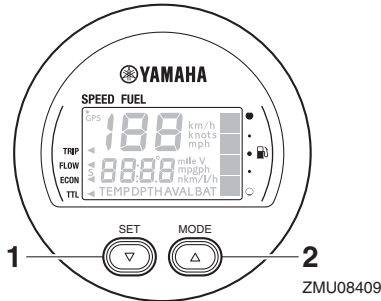

1. Set button
2. Mode button

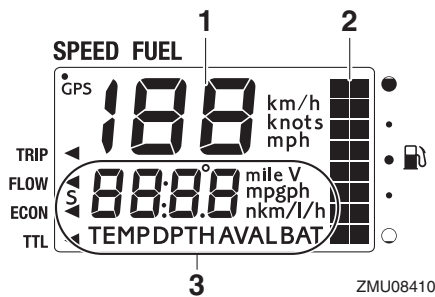

1. Speedometer
2. Fuel meter
3. Multifunction display

TIP:

The information displayed on the multifunction display can be changed. For information on other settings or changing

the displayed information, see the operation manual included with the 6Y8 Multifunction meter.

This manual mainly covers the alert display of the 6Y8 Multifunction tachometer. See the following sections for information about the alert indicators.

Indicators

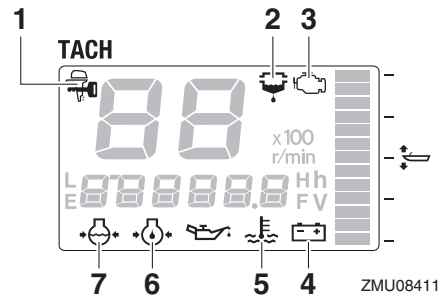

1. Yamaha Security System indicator (optional)
2. Water separator-alert indicator
3. Engine trouble-alert indicator
4. Battery voltage indicator
5. Overheat-alert indicator
6. Low oil pressure-alert indicator
7. Cooling water pressure indicator (optional)

Yamaha Security System indicator (optional)

This indicator appears, when the Yamaha Security System is in lock mode.

Lock mode

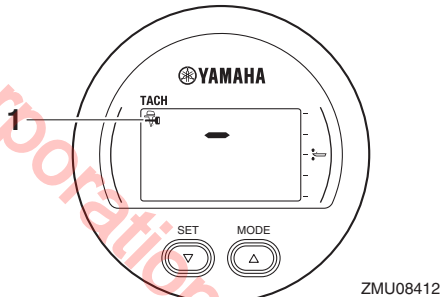

1. Yamaha Security System indicator (optional)

Make sure that the Yamaha Security System indicator is off before starting the engine.

Water separator-alert indicator

If water has accumulated in the water separator (fuel filter) while cruising, the water separator-alert indicator will start to blink.

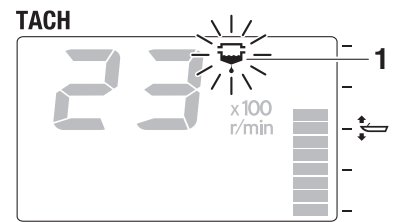

1. Water separator-alert indicator

Stop the engine immediately and see page 75 of this manual to drain the water from the fuel filter. Get back to the port soon and consult a Yamaha dealer immediately.

ECM00911

NOTICE

Gasoline mixed with water could cause damage to the engine.

Engine trouble-alert indicator

If the engine malfunctions while cruising, the engine trouble-alert indicator will start to blink. Get back to the port soon and consult a Yamaha dealer immediately.

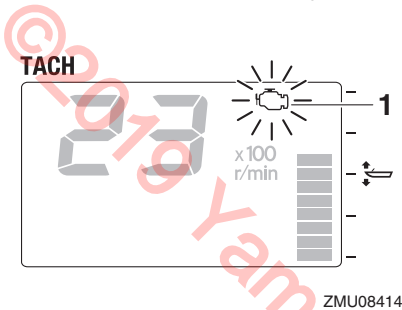

1. Engine trouble-alert indicator

ECM00921

NOTICE

In such an event, the engine will not operate properly. Consult a Yamaha dealer immediately.

Low battery voltage alert

If the battery voltage drops, the battery voltage value will start to blink.

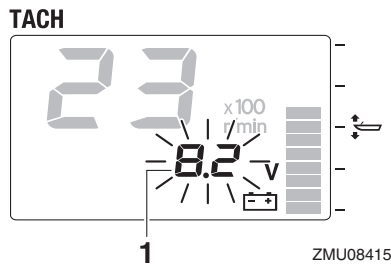

1. Battery voltage value

Get back to the port soon if the low battery voltage alert device has activated. For charging the battery, consult your Yamaha dealer.

Overheat-alert indicator

If the engine temperature rises too high while cruising, the overheat-alert indicator will start to blink, and the engine speed will automatically decrease to about 2000 r/min.

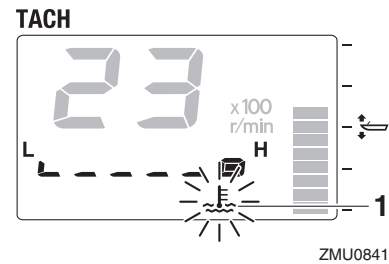

1. Overheat-alert indicator

Stop the engine immediately if the buzzer sounds and the overheat device has activated. Check the cooling water inlet for clogging.

ECM01594

NOTICE

- Do not continue to run the engine if the overheat-alert indicator blinks. Serious engine damage will occur.
- Do not continue to operate the engine if an alert device has activated. Consult your Yamaha dealer if the problem cannot be located and corrected.

Low oil pressure-alert indicator

If the engine oil pressure drops too low, the low oil pressure-alert indicator will start to blink, and the engine speed will automatically decrease to about 2000 r/min.

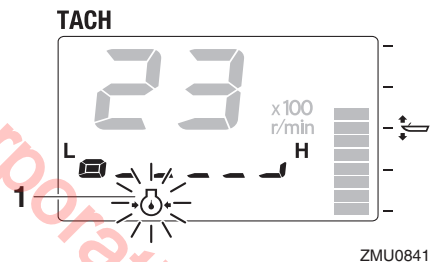

1. Low oil pressure-alert indicator

Stop the engine immediately if the buzzer sounds and the low oil pressure-alert indicator blinks. Check the engine oil quantity and replenish oil if necessary. If the alert device has activated while the appropriate engine oil quantity is maintained, consult your Yamaha dealer.

ECM01602

NOTICE

Do not continue to run the engine if the low oil pressure alert device has activated. Serious engine damage will occur.

Engine control system

EMU26805

Alert system

ECM00093

NOTICE

Do not continue to operate the engine if an alert device has activated. Consult your Yamaha dealer if the problem cannot be located and corrected.

EMU35185

Digital Electronic Control alert

If during operation of the outboard motor any communication troubles between the digital electronic control and the outboard motor occur, the alert indicator will light. Even if there is no symptom of trouble on shifting or throttle, get back to the port soon and have a Yamaha dealer inspect or repair the outboard motor.

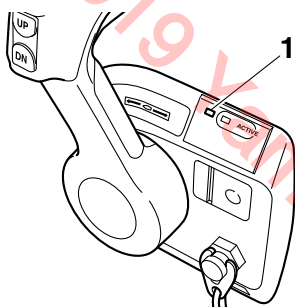

ZMU06227

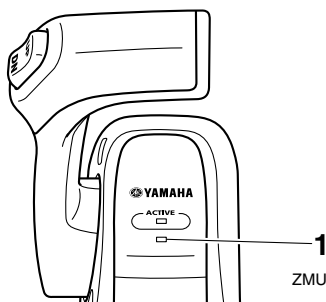

ZMU05889

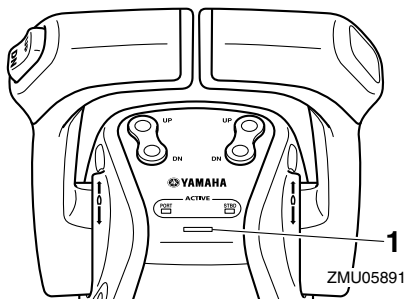

ZMU05891

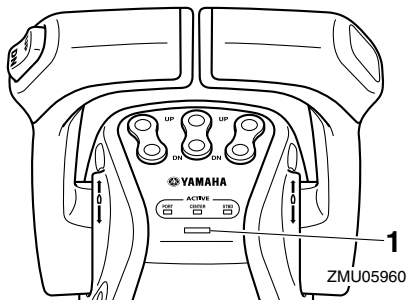

ZMU05960

1. Digital electronic control-alert indicator

EMU42113

Overheat alert

This engine has an overheat-alert device. If the engine temperature rises too high, the alert device will activate.

- The engine speed will automatically decrease to about 2000 r/min.
- The overheat-alert indicator of the 6Y8 Multifunction Tachometer will light or blink.

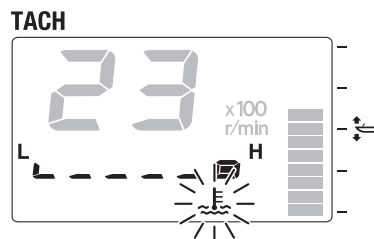

ZMU05422

- The pop-up window will appear on the Multi-Display.

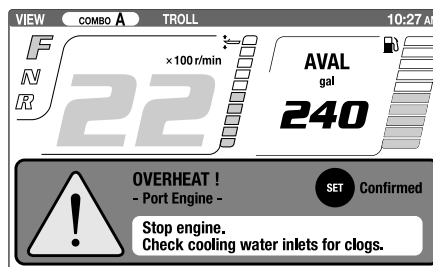

ZMU07238

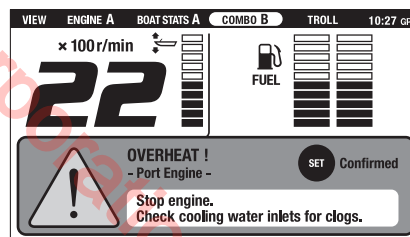

ZMU08533

- The buzzer will sound.



ZMU04583

Engine control system

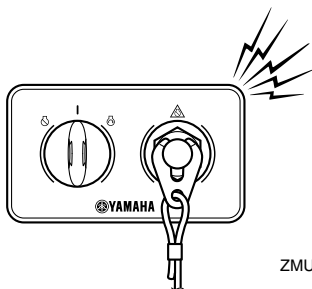

ZMU07155

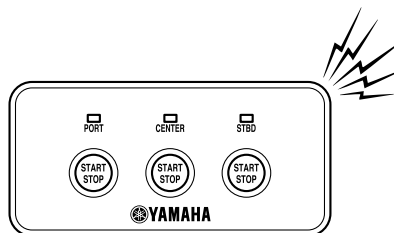

ZMU07334

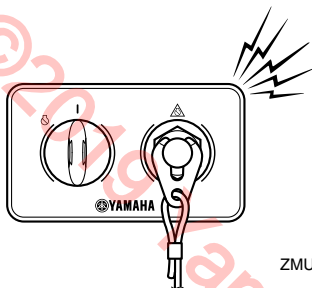

ZMU07156

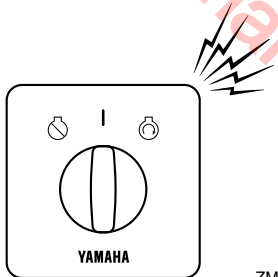

ZMU06297



ZMU07332

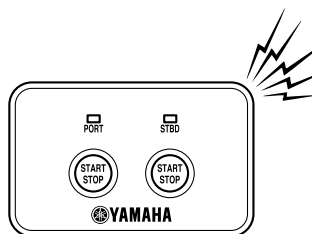

ZMU07333

If the alert system has activated, stop the engine and check the cooling water inlets:

- Check trim angle to be sure that the cooling water inlet is submerged.
- Check the cooling water inlet for clogging.

Multiple engine drive users:

If the overheat alert system of one engine activates, the engine will slow down. To switch off the alert activation on the engine not affected by overheating, turn off the main switch of the engine overheating. If the alert system has activated, stop the engine and tilt the outboard motor up to check the cooling water inlet for clogging. If the alert system has still activated, tilt the overheated outboard motor up and return to the port.

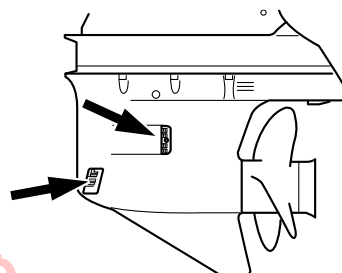

ZMU05826

EMU42132

Low oil pressure alert

If the oil pressure drops too low, the alert device will activate.

- The engine speed will automatically decrease to about 2000 r/min.
- The low oil pressure-alert indicator of the 6Y8 Multifunction Tachometer will light or blink.

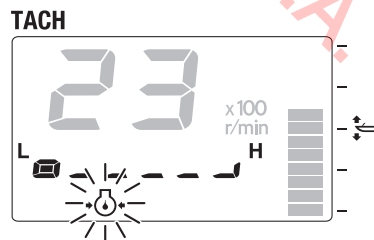

ZMU05431

- The pop-up window will appear on the Multi-Display.

Engine control system

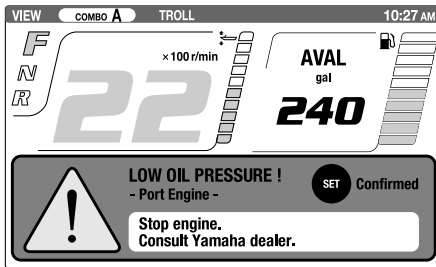

ZMU07240

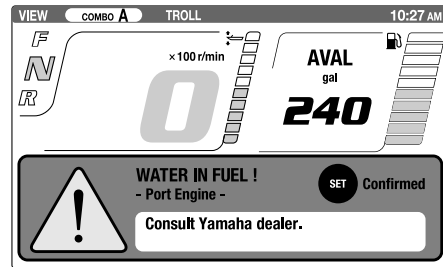

ZMU07242

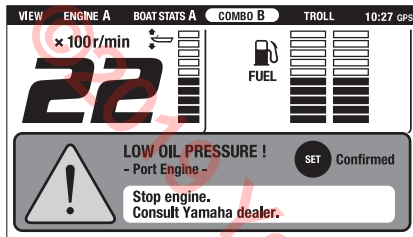

ZMU08534

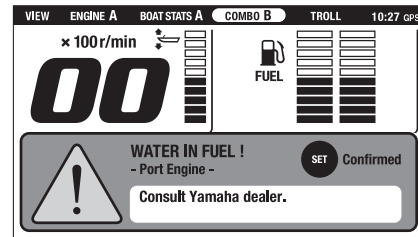

ZMU08535

- The buzzer will sound in the same way as during an over-heating alert.

If the alert device has activated, stop the engine as soon as it is safe to do so. Check the oil level and add oil as needed. If the oil level is correct and the alert device does not switch off, consult your Yamaha dealer.

Multiple engine drive users:

If the low oil pressure alert system of one engine activates, all of the engines will slow down and the buzzer will sound. To switch off the alert activation on the engine(s) not affected by low oil pressure, turn off the main switch of the engine with the low oil pressure.

EMU42152

Water separator alert

The outboard motor is equipped with a water separator alert system. If water separated from the fuel exceeds a specific volume, the alert system will activate.

- The water separator-alert indicator of the 6Y8 Multifunction Tachometer will come on or blink.

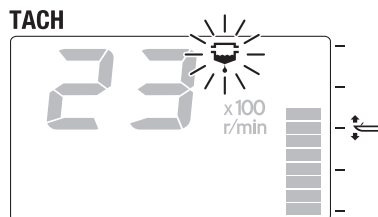

ZMU05424

- The pop-up window will appear on the Multi-Display.

- The buzzer will sound intermittently when the control lever is in the neutral position.

If the alert system has activated, stop the engine and see page 75 of this manual to drain the water from the fuel filter. Get back to the port soon and consult a Yamaha dealer immediately.

ECM02471

NOTICE

Although the buzzer will stop when the engine is started and the control lever is moved to the forward or reverse position, do not use the outboard motor. Otherwise, serious engine damage could occur.

EMU26903

Installation

The information presented in this section is intended as reference only. It is not possible to provide complete instructions for every possible boat and motor combination. Proper mounting depends in part on experience and the specific boat and motor combination.

EWMO1591

WARNING

- **Overpowering a boat could cause severe instability. Do not install an outboard motor with more horsepower than the maximum rating on the capacity plate of the boat. If the boat does not have a capacity plate, consult the boat manufacturer.**
- **Improper mounting of the outboard motor could result in hazardous conditions such as poor handling, loss of control, or fire hazards. For permanently mounted models, your dealer or other person experienced in proper rigging should mount the motor.**

EMU35812

Mounting the outboard motor

The outboard motor should be mounted so that the boat is well balanced. Otherwise, the boat could be hard to steer. For single-engine boats, mount the outboard motor on the centerline (keel line) of the boat.

For twin engine boats, mount the outboard motors equidistant from the centerline.

For triple engine boats, mount the center outboard motor on the centerline (keel line), and the port side and starboard side outboard motors equidistant from the center outboard motor.

Consult your Yamaha dealer or boat manufacturer for further information on determining the proper mounting location.

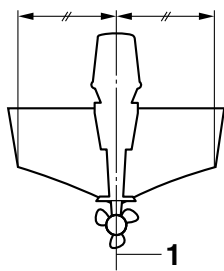

ZMU01760

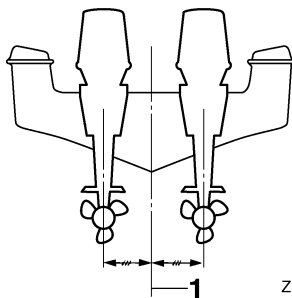

ZMU05141

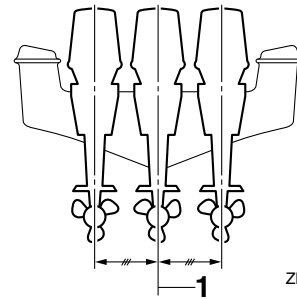

ZMU05957

1. Center line (keel line)

EMU26936

Mounting height (boat bottom)

The mounting height of your outboard motor affects its efficiency and reliability. If it is mounted too high, propeller ventilation may occur, which will reduce propulsion due to excessive propeller slip, and the water intakes for the cooling system may not get an adequate water supply, which can cause engine overheating. If the engine is mounted too low, water resistance (drag) will increase, thereby reducing engine efficiency and performance.

Most commonly, outboard motor should be mounted so that the anti-cavitation plate is in alignment with the bottom of the boat. The optimum mounting height of the outboard motor is affected by the boat/motor combination and the desired use. Test runs at different heights can help determine the optimum mounting height. Consult your Yamaha dealer or boat manufacturer for further information on determining the proper mounting height.

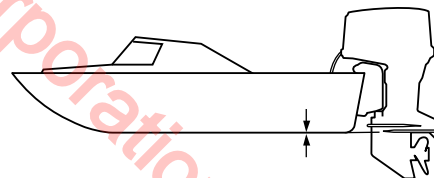

ZMU01762

ECM01635

NOTICE

- **Make sure that the idle hole is high enough to prevent water from entering the engine even if the boat is stationary with the maximum load.**
- **Incorrect engine height or obstructions to the smooth flow of water (such as the design or condition of the boat, or accessories, such as transom ladders or depth finder transducers) can create airborne water spray while the boat is cruising. If the outboard motor is operated continuously in the presence of airborne water spray, enough water can enter the engine through the air intake opening in the top cowling to cause severe engine damage. Remove the cause of the airborne water spray.**

Operation

EMU36382

First-time operation

EMU36393

Fill engine oil

The engine is shipped from the factory without engine oil. If your dealer did not fill the oil, you must fill it before starting the engine. **NOTICE: Check that the engine is filled with oil before first-time operation to avoid severe engine damage.** [ECM01782]

The engine is shipped with the following tag, which should be removed after engine oil is filled for the first time. For more information on checking the engine oil level, see page 42.

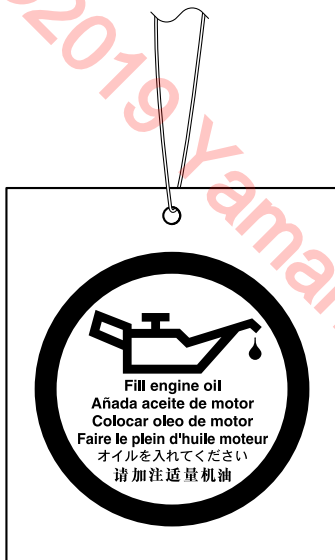

ZMU01710

EMU30175

Breaking in engine

Your new engine requires a period of break-in to allow mating surfaces of moving parts to wear in evenly. Correct break-in will help ensure proper performance and longer engine life. **NOTICE: Failure to follow the break-in procedure could result in reduced engine life or even severe engine damage.** [ECM00802]

EMU27086

Procedure for 4-stroke models

Your new engine requires a period of 10 hours break-in to allow mating surfaces of moving parts to wear in evenly.

TIP:

Run the engine in the water, under load (in gear with a propeller installed) as follows. For 10 hours for breaking in engine avoid extended idling, rough water and crowded areas.

1. For the first hour of operation:
Run the engine at varying speeds up to 2000 r/min or approximately half throttle.
2. For the second hour of operation:
Increase engine speed as much as necessary to put the boat on plane (but avoid full-throttle operation), then back off on the throttle while keeping the boat at a planing speed.
3. Remaining 8 hours:
Run the engine at any speed. However, avoid operating

at full throttle for more than 5 minutes at a time.

4. After the first 10 hours:
Operate the engine normally.

EMU36402

Getting to know your boat

All boats have unique handling characteristics. Operate cautiously while you learn how your boat handles under different conditions and various trim angles (see page 56).

EMU36414

Checks before starting engine

EWM01922

WARNING

If any item in "Checks before starting engine" is not working properly, have it inspected and repaired before operating the outboard motor. Otherwise, an accident could occur.

ECM00121

NOTICE

Do not start the engine out of water. Overheating and serious engine damage can occur.

EMU36422

Fuel level

Be sure you have plenty of fuel for your trip. A good rule is to use 1/3 of your fuel to get to the destination, 1/3 to return, and to keep 1/3 as an emergency reserve. With the boat level on a trailer or in the water, turn the key to "ON" (on) and check the fuel level. For fuel filling instructions, see page 44.

EMU40774

Removing top cowling

For the following checks, remove the top cowling from the bottom cowling.

To remove the top cowling, pull the cowling lock levers and lift up the top cowling.

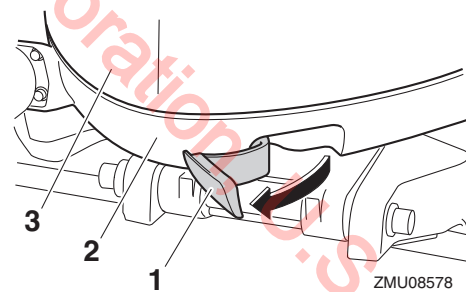

1. Cowling lock lever
2. Bottom cowling
3. Top cowling

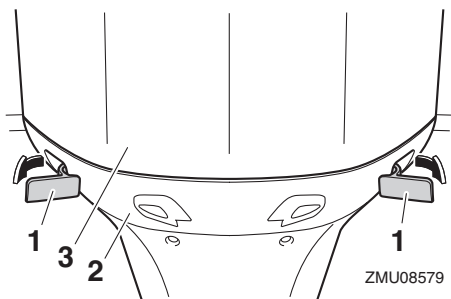

1. Cowling lock lever(s)
2. Bottom cowling
3. Top cowling

EMU36443

Fuel system

EWMO0061

⚠ WARNING

Gasoline and its vapors are highly flammable and explosive. Keep away from sparks, cigarettes, flames, or other sources of ignition.

EWMO0911

⚠ WARNING

Leaking fuel can result in fire or explosion.

- Check for fuel leakage regularly.
- If any fuel leakage is found, the fuel system must be repaired by a qualified mechanic. Improper repairs can make the outboard unsafe to operate.

EMU36453

Check for fuel leaks

- Check for fuel leaks or gasoline fumes in the boat.
- Check for fuel leakage from the fuel system.
- Check the fuel tank and fuel lines for cracks, swellings, or other damage.

EMU36472

Check the fuel filter

Check that the fuel filter is clean and free of water. If enough water to raise the float ring is found in the fuel, or if a significant amount of debris is found, the fuel tank should be checked and cleaned by a Yamaha dealer.

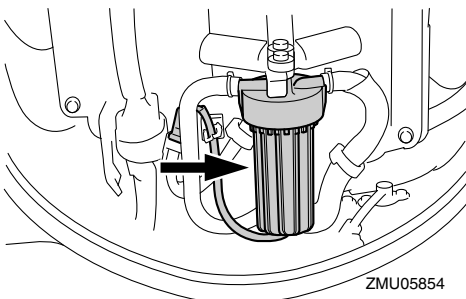

EMU41771

Controls

- Turn the main switch "ON" (on) and make sure that the Digital electronic control-active indicator comes on.
- Turn the steering wheel full-right and full-left. Make sure operation is smooth and unrestricted throughout the whole range with no binding or excessive free play.

- Operate the throttle levers several times to make sure there is no hesitation in their travel. Operation should be smooth over the complete range of motion, and each lever should return completely to the idle position.

EMU40363

Engine shut-off cord (lanyard)

Check the engine shut-off cord and clip for damage, such as cuts, breaks, and wear.

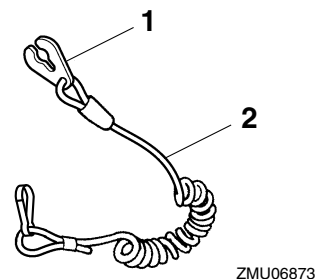

1. Clip
2. Engine shut-off cord (lanyard)

EMU40994

Engine oil

1. Place the outboard motor in a vertical position (not tilted). **NOTICE: If the outboard motor is not level, the oil level indicated on the oil dipstick may not be accurate.** [ECM01862]
2. Remove the oil dipstick and wipe it clean.

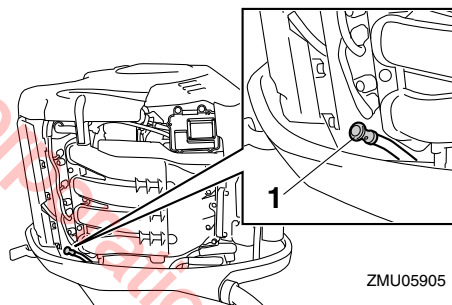

1. Oil dipstick
3. Insert the oil dipstick completely and remove it again.
4. Check that the oil level on the oil dipstick is between the upper and lower marks. Consult your Yamaha dealer if the oil level is not at the proper level or if it appears milky or dirty.

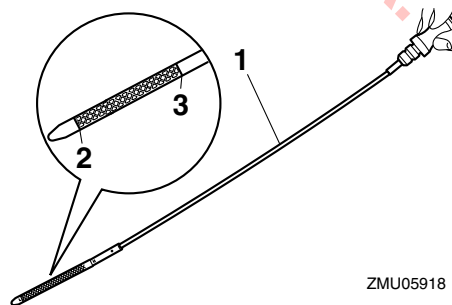

1. Oil dipstick
2. Lower mark
3. Upper mark

Operation

EMU27154

Engine

- Check the engine and engine mounting.
- Look for loose or damaged fasteners.
- Check the propeller for damage.
- Check for engine oil leaks.

EMU36494

Flushing device

Check that the flushing device's garden hose connector is securely screwed on to the fitting on the bottom cowling.

NOTICE: If the garden hose connector is not properly connected, cooling water can leak out and the engine can overheat during operation. [ECM01802]

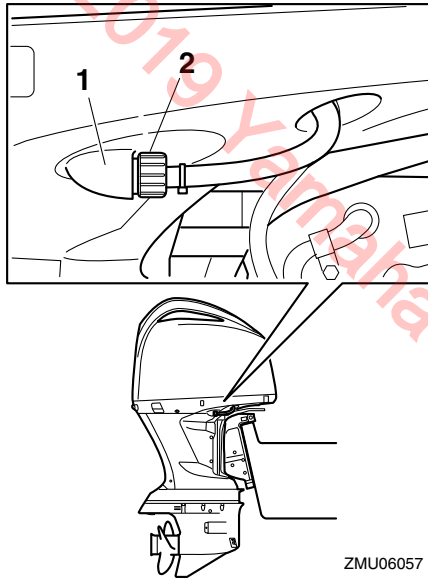

1. Fitting
2. Flushing device

EMU40752

Installing top cowling

1. Check the rubber seal for damage. If the rubber seal is damaged, have it replaced by a Yamaha dealer.

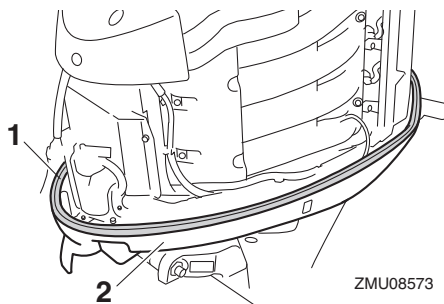

1. Rubber seal
2. Bottom cowling

2. Check that the rubber seal is seated all the way around the bottom cowling.
3. Check that all of the cowling lock levers are pulled outward.
4. Align the 3 protrusions on the top cowling with the cor-

responding holders on the bottom cowling, and then place the top cowling on the bottom cowling.

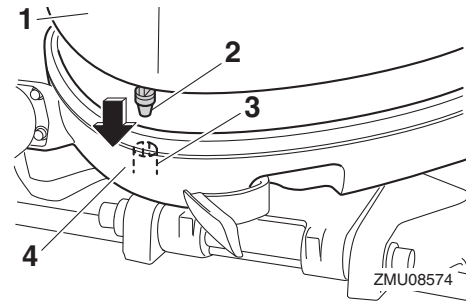

1. Top cowling
2. Protrusion
3. Holder
4. Bottom cowling

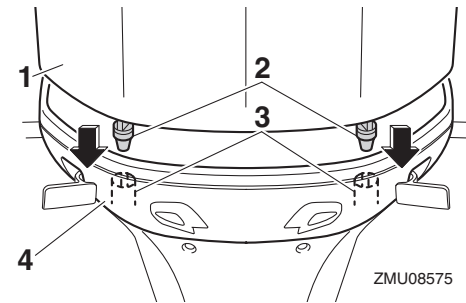

1. Top cowling
2. Protrusion
3. Holder
4. Bottom cowling

5. Push the cowling lock levers inward to secure the top cowling.

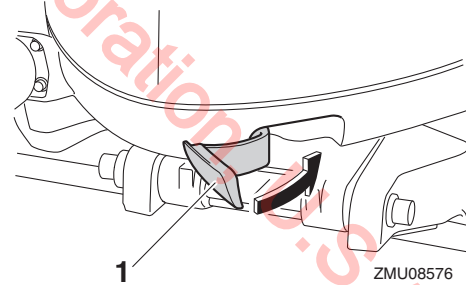

1. Cowling lock lever

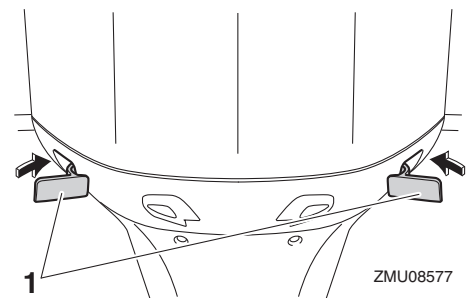

1. Cowling lock lever(s)

- Check the fitting of the top cowling by pushing it with both hands. **NOTICE: If the top cowling is not installed correctly, water can enter the top cowling and damage the engine, or the top cowling can blow off at high speeds.** [ECM02371]

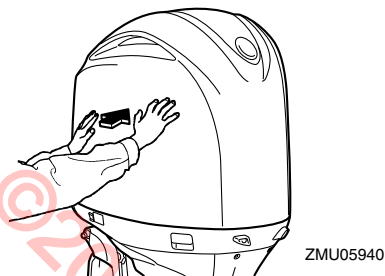

ZMU05940

EMU35245

Checking power trim and tilt system

EWM01931

⚠ WARNING

- Never get under the lower unit while it is tilted, even when the tilt support lever is locked. Severe injury could occur if the outboard motor accidentally falls.
- Body parts can be crushed between the motor and the clamp bracket when the motor is trimmed or tilted.
- Be sure no one is near the outboard motor before performing this check.

- Check the power trim and tilt unit for any sign of oil leaks.
- Operate each of the power trim and tilt switches on the digital electronic control and engine bottom cowling (if equipped) to check that all switches work.
- Tilt the outboard motor up and check that the tilt rod and trim rods are extended completely.

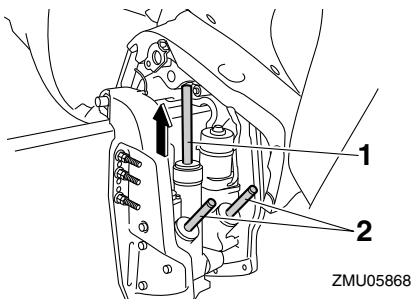

ZMU05868

- Tilt rod
 - Trim rods
- Use the tilt support lever to lock the motor in the up position. Operate the tilt down switch briefly so the motor is supported by the tilt support lever.

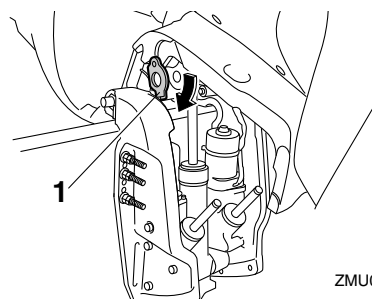

ZMU05869

- Tilt support lever
- Check that the tilt rod and trim rods are free of corrosion or other flaws.
 - Activate the tilt-down switch until the trim rods have retracted completely into the cylinders.

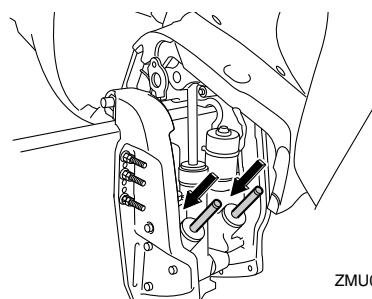

ZMU05855

- Activate the trim-up switch until the tilt rod is fully extended. Unlock the tilt support lever.
- Tilt the outboard motor down. Check that the tilt rod and trim rods operate smoothly.

EMU36585

Battery

Check the battery's charge. If your boat is equipped with a Yamaha digital speedometer, the voltmeter and low battery alert functions will help you monitor the battery's charge. A battery in good condition will provide a minimum of 12 volts. Check that the battery connections are clean, secure and covered by insulating covers. The electrical connections of the battery and cables must be clean and properly connected or the battery will not start the engine. If the battery needs charging, consult your Yamaha dealer or the battery manufacturer's instructions.

EMU30027

Filling fuel

EWM01831

⚠ WARNING

- Gasoline and its vapors are highly flammable and explosive. Always refuel according to this procedure to reduce the risk of fire and explosion.
- Gasoline is poisonous and can cause injury or death. Handle gasoline with care. Never siphon gasoline by mouth. If you should swallow some gasoline or inhale a lot of gasoline vapor, or get some gasoline in your eyes, see your doctor immediately. If gasoline spills on your skin, wash with soap and water. If gasoline spills on your clothing, change your clothes.

- Make sure that the engine is stopped.

Operation

2. Make sure that the boat is in a well-ventilated outdoor area, either securely moored or trailered.
3. Make sure that no one is in the boat.
4. Do not smoke and keep away from sparks, flames, static electric discharge, or other sources of ignition.
5. If you use a portable container to store and dispense fuel, only use a locally approved GASOLINE container.
6. Touch the fuel nozzle to the filler opening or funnel to help prevent electrostatic sparks.
7. Fill the fuel tank, but do not overfill. **WARNING! Do not overfill. Otherwise fuel can expand and overflow if the temperature increases.** [EWM02611]
8. Tighten the fuel tank cap securely.
9. Wipe up any spilled gasoline immediately with dry rags. Dispose of rags properly according to local laws or regulations.

EMU27453

Operating engine

EWM00421

⚠ WARNING

- Before starting the engine, make sure that the boat is tightly moored and that you can steer clear of any obstructions. Be sure there are no swimmers in the water near you.
- When the air vent screw is loosened, gasoline vapor will be released. Gasoline is highly flammable, and its vapors are flammable and explosive. Refrain from smoking, and keep away from open flames and sparks while loosening the air vent screw.
- This product emits exhaust gases which contain carbon monoxide, a colorless, odorless gas which could cause brain damage or death when inhaled. Symptoms include nausea, dizziness, and drowsiness. Keep cockpit and cabin areas well ventilated. Avoid blocking exhaust outlets.

EMU31814

Sending fuel

1. If there is a fuel joint or a fuel valve on the boat, firmly connect the fuel line to the joint or open the fuel valve.
2. Squeeze the primer pump, with the arrow pointing up, until you feel it become firm.

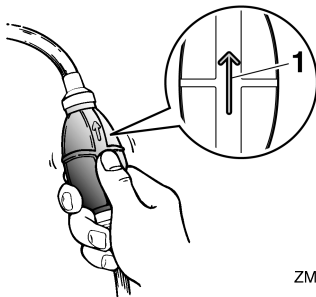

ZMU02025

1. Arrow

EMU27495

Starting engine

EWM01601

⚠ WARNING

Before starting the engine, make sure that the boat is

tightly moored and that you can steer clear of any obstructions. Be sure there are no swimmers in the water near you.

EMU41791

Start-up checks

Place the control lever in neutral and turn the main switch to "ON" (on). Make sure that no alert-indicator comes on. If the buzzer sounds and the water separator-alert indicator blinks, consult your Yamaha dealer immediately.

EMU46880

Procedure for starting engine

EWM01842

⚠ WARNING

- Failure to attach the engine shut-off cord could result in a runaway boat if operator is ejected. Attach the engine shut-off cord to a secure place on your clothing, or your arm or leg while operating. Do not attach the cord to clothing that could tear loose. Do not route the cord where it could become entangled, preventing it from functioning.
- Avoid accidentally pulling the cord during normal operation. Loss of engine power means the loss of most steering control. Also, without engine power, the boat could slow rapidly. This could cause people and objects in the boat to be thrown forward.

1. Place the control lever in "N" (neutral).

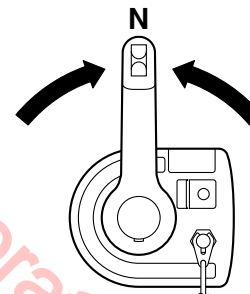

ZMU06236

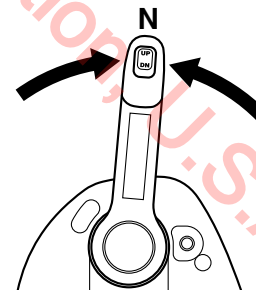

ZMU05829

TIP:

The start-in-gear protection device prevents the engine from starting except when in neutral.

2. Attach the engine shut-off cord to a secure place on your clothing, or your arm or leg. Then install the clip on the other end of the cord into the engine shut-off switch.

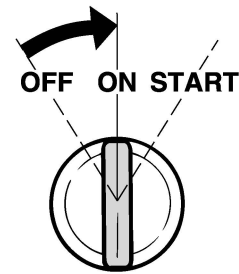
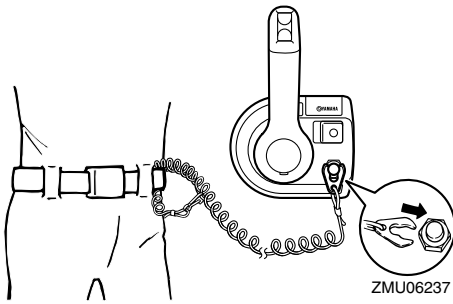

- Turn the main switch to "START" (start), and hold it for a maximum of 5 seconds. **NOTICE:** Never turn the main switch to "START" (start) while the engine is running. Do not keep the starter motor turning for more than 5 seconds. If the starter motor is turned continuously for more than 5 seconds, the battery will be quickly discharged, thus making it impossible to start the engine. The starter can also be damaged. If the engine will not start after 5 seconds of cranking, return the main switch to "ON" (on), wait 10 seconds, then crank the engine again. [ECM00193]

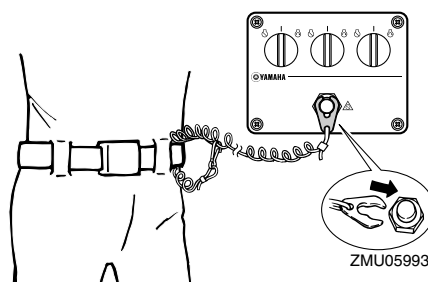
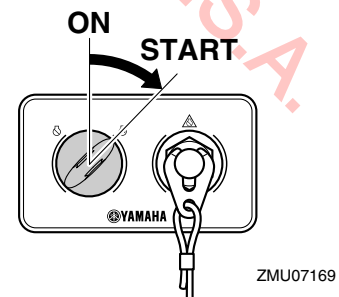
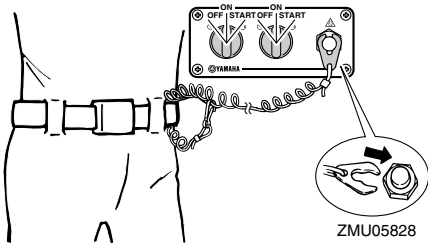
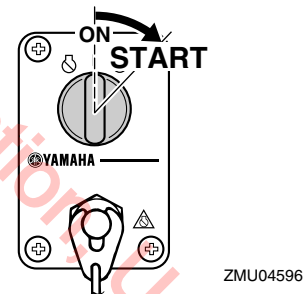
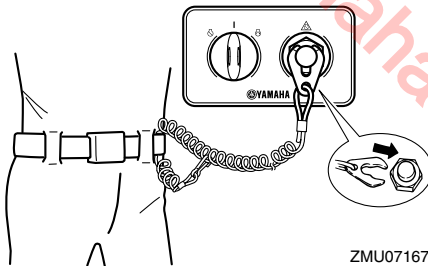
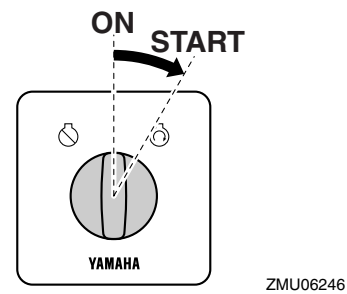
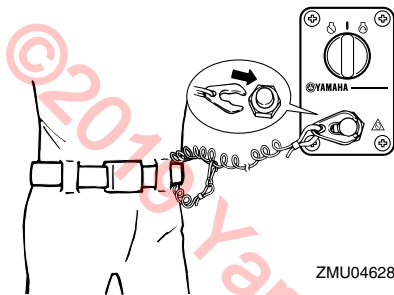

- Turn the main switch to "ON" (on) to make sure that the digital electronic control-active indicator lights. The engine can not be started when the digital electronic control-alert indicator lights.

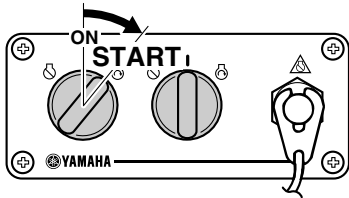

ZMU05830

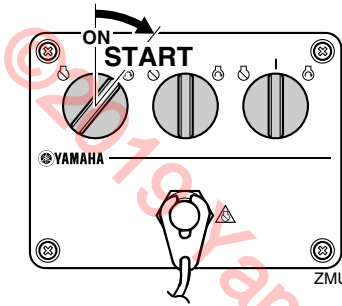

ZMU05994

When starting the engine using the Start/Stop button, press the button to start the engine. The indicator for the starting engine will come on.

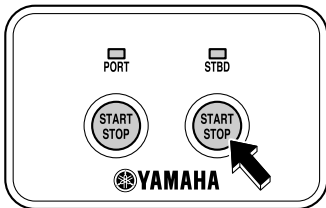

ZMU07148

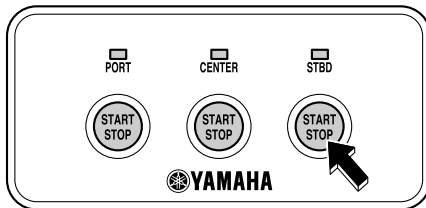

ZMU07149

When starting the engine using the Start/Stop button on the All Start/Stop switch panel, press the button to start the all engines.



ZMU07150

TIP:

- When the main switch is turned to “START” (start) with the clip removed from the engine shut-off switch, the buzzer will sound.
- Except the single type, if the clip is not installed to the engine shut-off switch, the buzzer will sound when the Start/Stop button is pressed.
- Except the single type, if one of the engines has started, it can be stopped by pressing the Start/Stop button on the All Start/Stop switch panel.

EMU36511

Checks after starting engine

EMU41361

Cooling water

Check for a steady flow of water from the cooling water pilot hole. A continuous flow of water from the cooling water pilot hole shows that the water pump is pumping water through the cooling water passages.

TIP:

When the engine is started, there may be a slight delay before water flows from the cooling water pilot hole.

ECM02251

NOTICE

If water is not flowing out of the cooling water pilot hole at all times while the engine is running, overheating and serious damage could occur. Stop the engine and check whether the cooling water inlet on the lower case or the cooling water pilot hole is blocked. Consult your Yamaha dealer if the problem cannot be located and corrected.

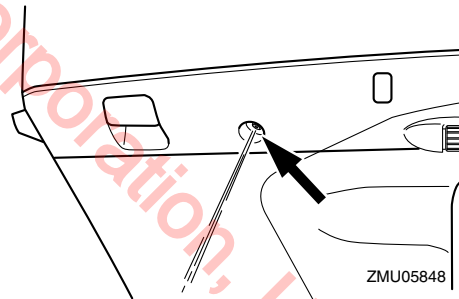

EMU27671

Warming up engine

EMU41811

Electric start models

After the engine has started, warm up the engine until the engine speed settles at idling speed. The engine warming-up indicator is shown on the Multi-Display while the engine warms up. For further information, see page 30.

EMU36532

Checks after engine warm up

EMU36542

Shifting

While the boat is tightly moored, and without applying throttle, confirm that the engine shifts smoothly into forward and reverse, and back to neutral.

EMU41821

Stop switches

Perform the following procedure to check that the main

switch and engine shut-off switch operate properly.

- Check that the engine stops when the main switch is turned to the "OFF" (off) position, or press the Start/Stop button.
- Check that the engine stops when the clip is pulled from the engine shut-off switch.
- Check that the engine cannot be started with the clip removed from the engine shut-off switch.

EMU35881

Selecting outboard motor (triple engine)

After all engines have started, set all control levers to Neutral. Push the engine selector switch repeatedly to change the digital electronic control-active indicator and select the desired engine.

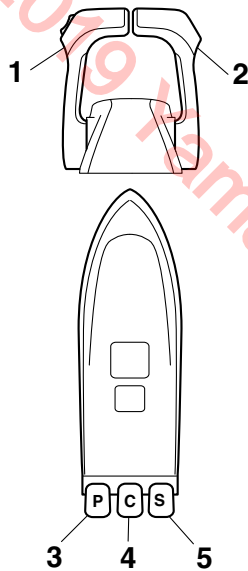

ZMU05998

1. Port side control lever
2. Starboard side control lever
3. Port side engine
4. Center engine
5. Starboard side engine

1. First, three engines can be operated.

TIP:

When all engines have started, the center engine will run at the average speed of port side and starboard side engines' speeds.

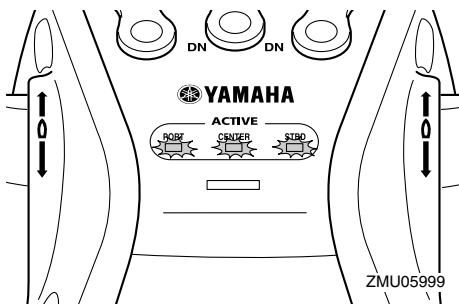

ZMU05999

- Operate the port side engine using the port side control lever.
- The center engine runs at the average speed of port side

and starboard side engines' speeds.

- Operate the starboard side engine using the starboard side control lever.
2. Push the engine selector switch once to operate the port side and starboard side engines.

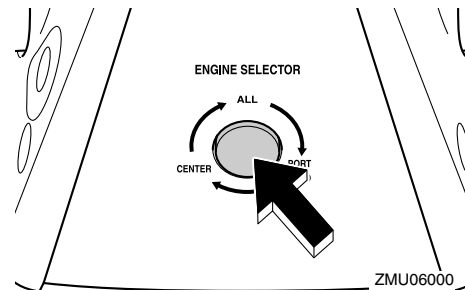

ZMU06000

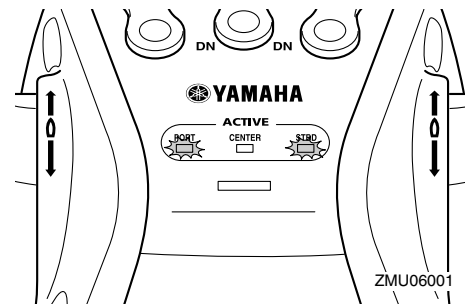

ZMU06001

- Operate the port side engine using the port side control lever.
 - The center engine runs at the idling speed.
 - Operate the starboard side engine using the starboard side control lever.
3. Push the engine selector switch twice to operate the center engine.

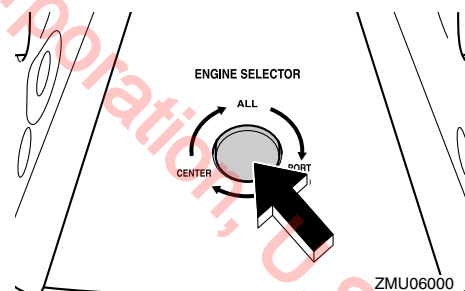

ZMU06000

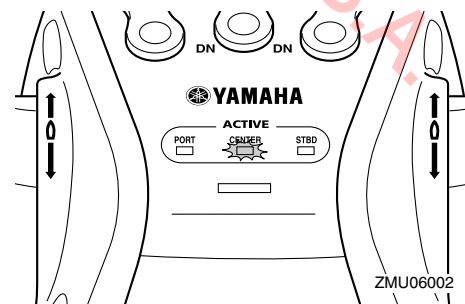

ZMU06002

- The port side engine runs at the idling speed.
 - Operate the center engine using the port side control lever.
 - The starboard side engine runs at the idling speed.
4. Push the engine selector switch three times to operate

Operation

the three engines.

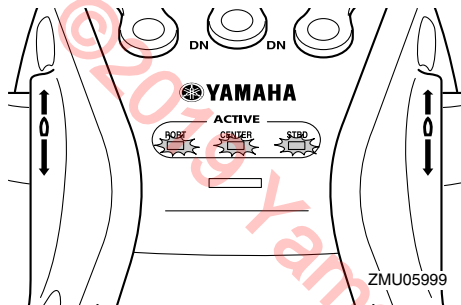
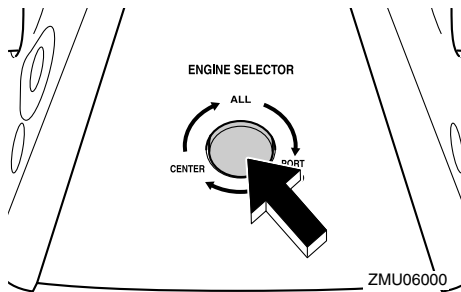

EMU35125

Shifting

EWWM00181

⚠ WARNING

Before shifting, make sure there are no swimmers or obstacles in the water near you.

Warm up the engine before shifting into gear. Until the engine is warm, the idle speed may be higher than normal. The control lever of the Digital electronic control can be operated even at high engine speeds. However, gear shifting will not work until the engine speed has automatically decreased to a speed at which actual gear shifting is possible. As a result, for quick gear shifting there could be a time lag when the gear is shifted until the engine speed has decreased sufficiently.

To shift out of neutral

1. Pull the neutral interlock trigger up (if equipped).

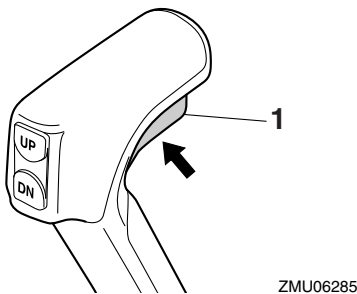

1. Neutral interlock trigger

2. Move the control lever firmly and crisply forward (for forward gear) or backward (for reverse gear) 22.5° (a detent can be felt).

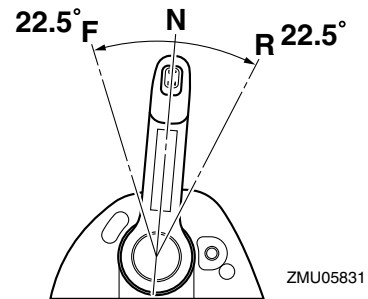
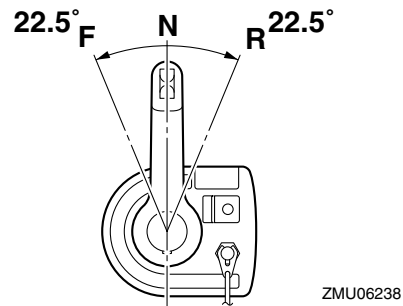

To shift from in gear (forward/reverse) to neutral

1. Close the throttle so that the engine slows to idle speed.

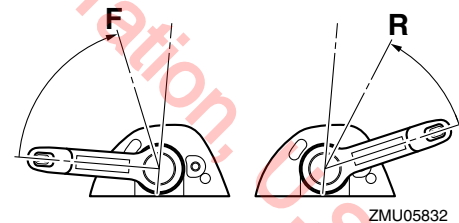
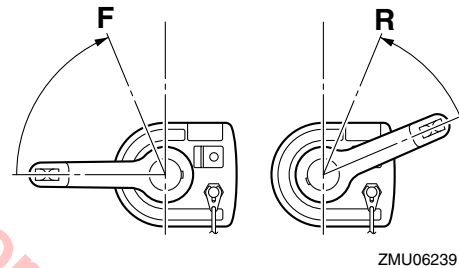

2. After the engine is at idle speed in gear move the control lever firmly and crisply into the neutral position.

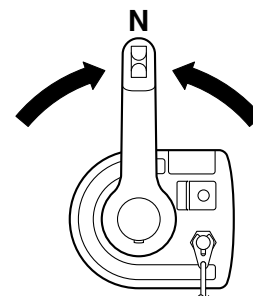

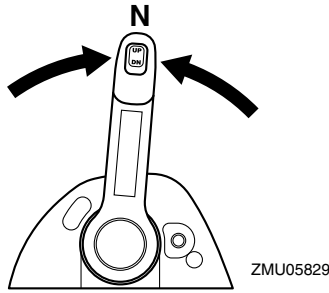

EMU31743

Stopping boat

EWM01511

⚠ WARNING

- Do not use the reverse function to slow down or stop the boat as it could cause you to lose control, be ejected, or impact the steering wheel or other parts of the boat. This could increase the risk of serious injury. It could also damage the shift mechanism.
- Do not shift into reverse while traveling at planing speeds. Loss of control, boat swamping, or damage to the boat could occur.

The boat is not equipped with a separate braking system. Water resistance stops it after the throttle lever is moved back to idle. The stopping distance varies depending on gross weight, water surface conditions, and wind direction.

EMU35892

Operating the port / center / starboard engine

The outboard motor to be used can be selected with the main switch or Start/Stop button.

ECM01741

NOTICE

Be sure to tilt the unoperated motor up. Otherwise water could enter the exhaust pipe due to the wave action, causing engine trouble.

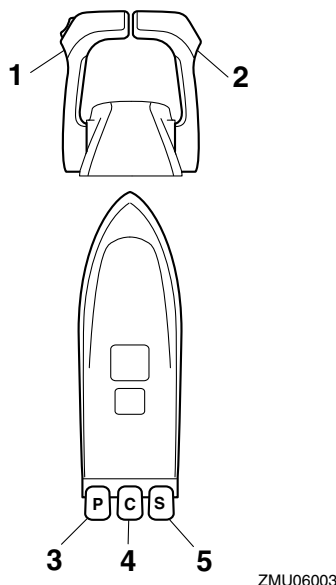

1. Port side control lever

2. Starboard side control lever
3. Port side engine
4. Center engine
5. Starboard side engine

Operating three outboard motors

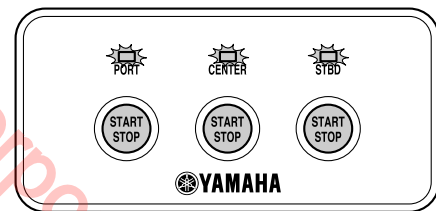
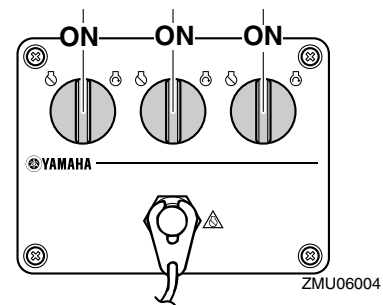
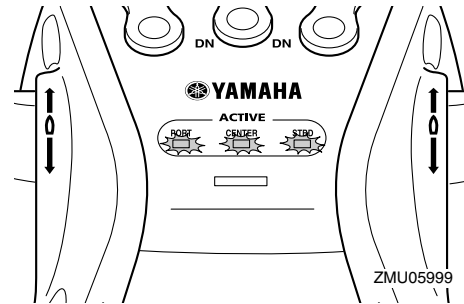

- Operate the port side engine using the port side control lever.
- When all engines have started, the center engine will run at the average speed of port side and starboard side engines' speeds.
- Operate the starboard side engine using the starboard side control lever.

Operating the port side engine and starboard side engine

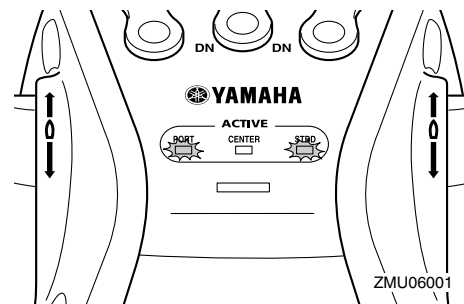

Operation

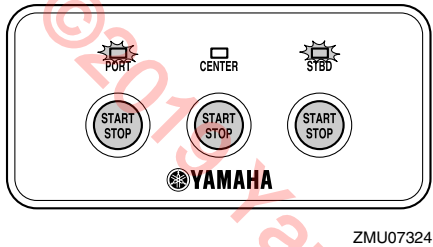
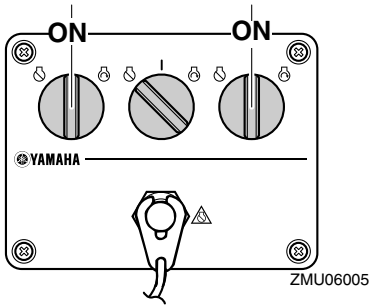

- Operate the port side engine using the port side control lever.
- Operate the starboard side engine using the starboard side control lever.

Operating the port side engine and center engine

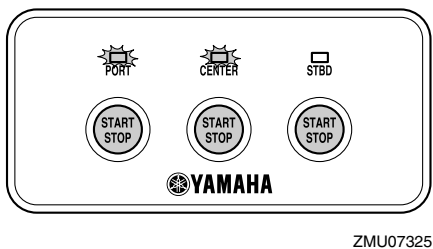
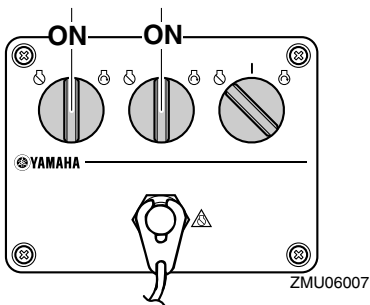
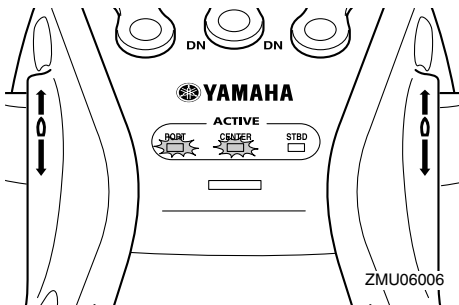

- Operate the port side engine using the port side control lever.

- Operate the center engine using the starboard side control lever.

Operating the center engine and starboard side engine

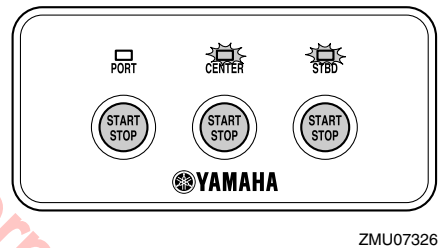
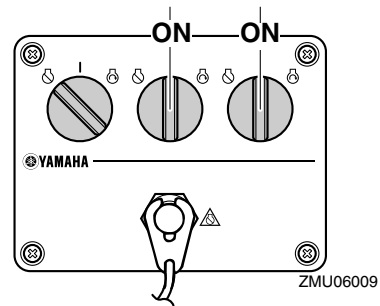
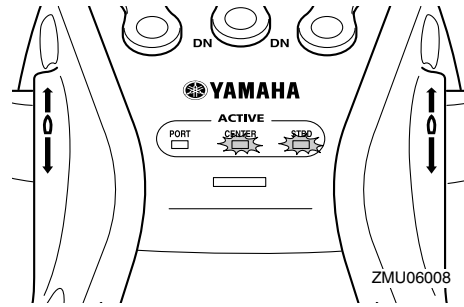

- Operate the center engine using the port side control lever.
- Operate the starboard side engine using the starboard side control lever.

Operating the center engine

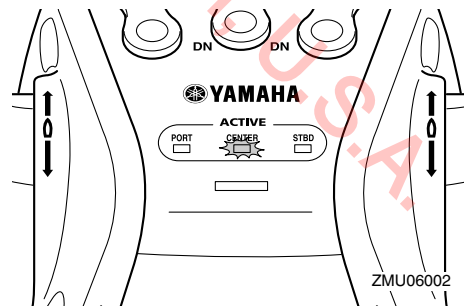

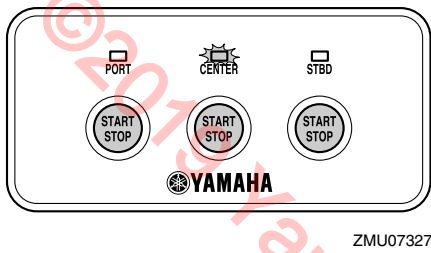
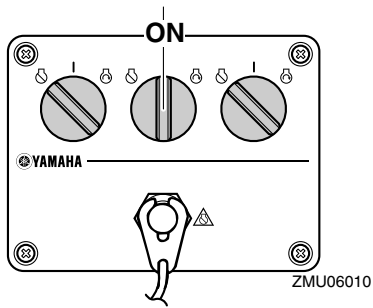

- Operate the center engine using the port side control lever.

©2017 Yamaha Motor Corporation, U.S.A.

Operation

EMU35902

Boat direction

The illustrations below indicate the boat direction when operating the three outboard motors.

When using the port side engine, center engine and starboard side engine

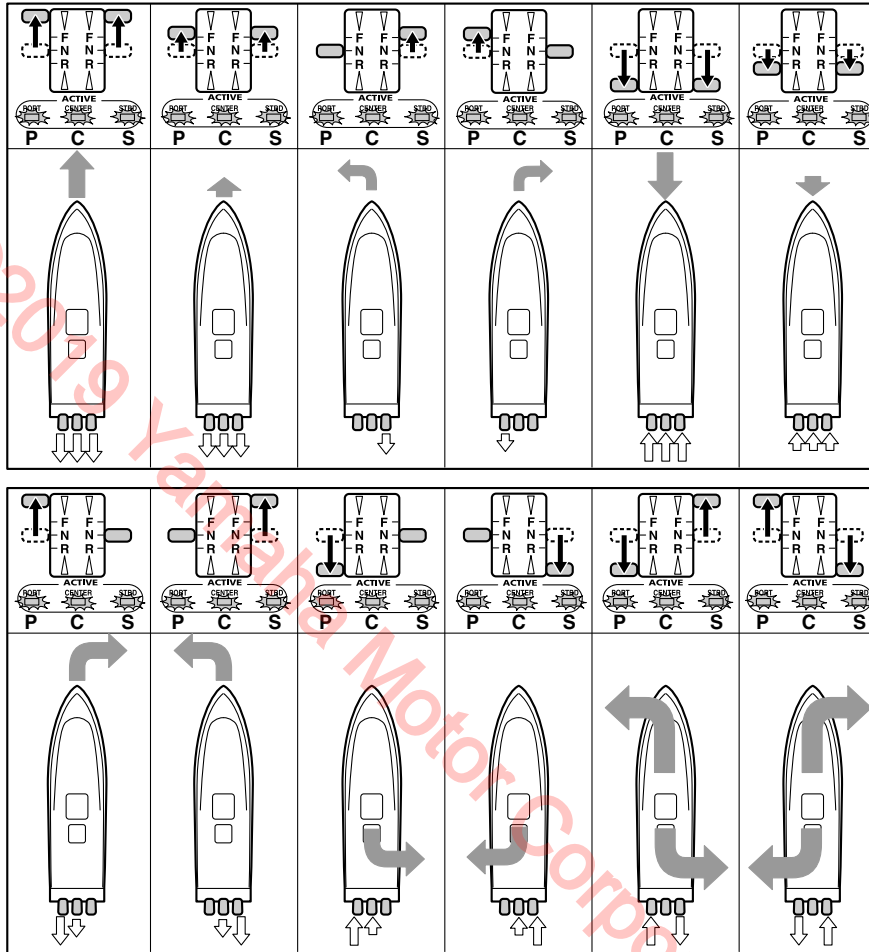

ZMU06011

←: Boat direction and turning force

The size of the arrow is proportional to the turning force.

⇄: Propulsion

When using the port side engine and starboard side engine

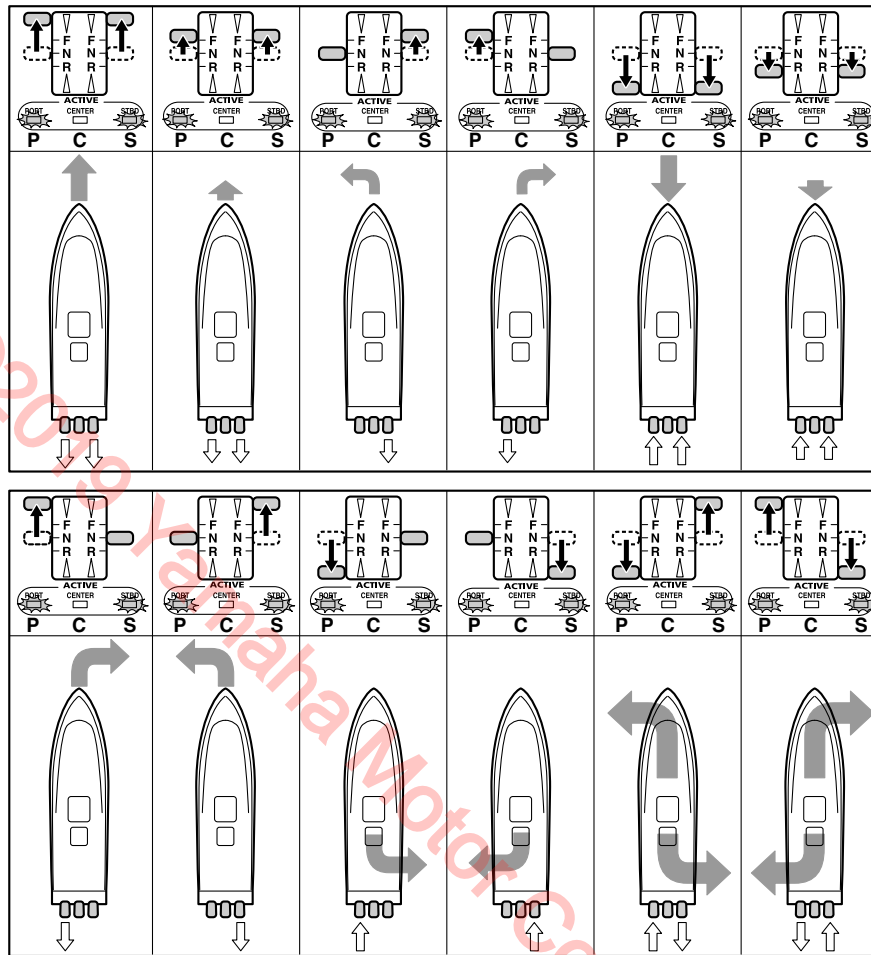

ZMU06012

←: Boat direction and turning force

The size of the arrow is proportional to the turning force.

⇄: Propulsion

When using the center engine

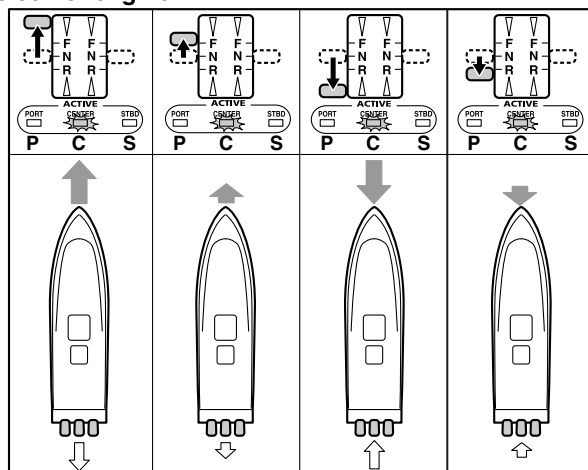

ZMU06013

←: Boat direction and turning force

The size of the arrow is proportional to the turning force.

⇄: Propulsion

Operation

EMU30881

Trolling

EMU41832

Adjusting trolling speed

When the control lever is either in the forward position or in the reverse position and the throttle is in the fully closed position, you can randomly adjust the trolling speed between 600 r/min and 1000 r/min by increasing or decreasing it approximately by 50 r/min. The display will show the engine speed when the engine speed is increased from the fully closed position during trolling speed setting mode. When the throttle is returned to the fully closed position, the display will show the trolling speed again. When the engine is turned off or when the engine speed exceeds 3000 r/min, trolling speed setting mode will be released.

For details, see the attached operation manual.

TACH

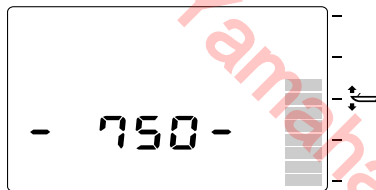

ZMU06309

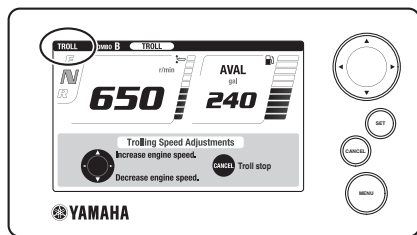

ZMU07256

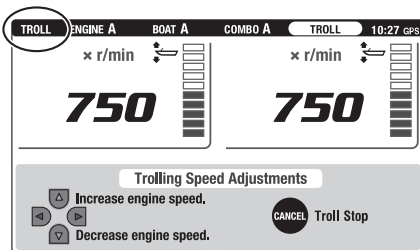

ZMU08536

TIP:

- Trolling is affected by currents and other operating conditions and may differ from the actual engine speed.
- When warming up a cold engine, the trolling speed cannot be decreased below the specified engine idle speed.

EMU27822

Stopping engine

Before stopping the engine, first let it cool off for a few minutes at idle or low speed. Stopping the engine immediately after operating at high speed is not recommended.

EMU41913

Procedure for stopping engine

1. The engine can be turned off either by pressing the Start/Stop button or by turning the main switch to the "OFF" (off) position. After the engine has been turned off using the Start/Stop button, turn the main switch to the "OFF" (off) position.

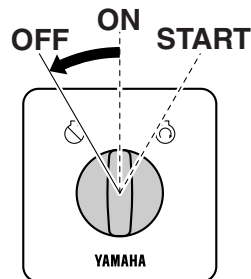

ZMU06247

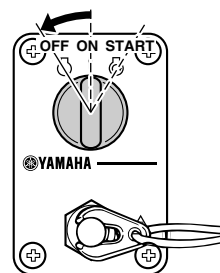

ZMU04599

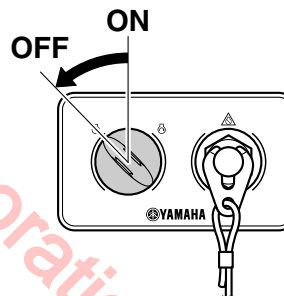

ZMU07171

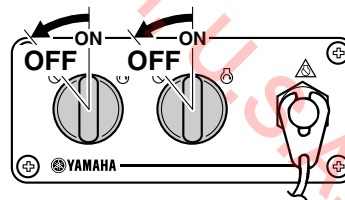

ZMU05833

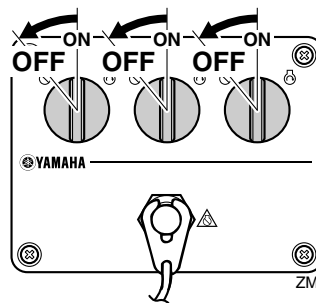

ZMU06014

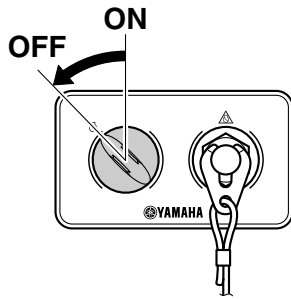

ZMU07172

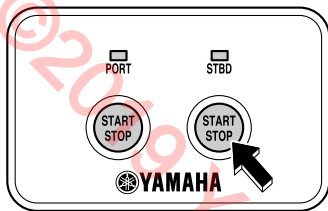

ZMU07148

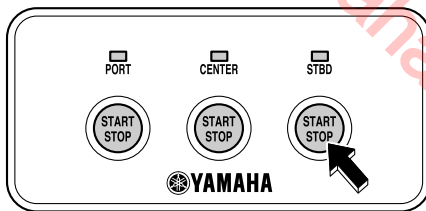

ZMU07149



ZMU07150

TIP:

- The engine can also be stopped by pulling the cord and removing the clip from the engine shut-off switch, then turning the main switch to "OFF" (off).
- 2. Remove the key if the boat will be left unattended.

EMU27865

Trimming outboard motor

EWMO0741

⚠ WARNING

Excessive trim for the operating conditions (either trim up or trim down) can cause boat instability and can make steering the boat more difficult. This increases the possibility of an accident. If the boat begins to feel unstable or is hard to steer, slow down and/or readjust the trim angle.

The trim angle of the outboard motor helps determine the position of the bow of the boat in the water. Correct trim an-

gle will help improve performance and fuel economy while reducing strain on the engine. Correct trim angle depends upon the combination of boat, engine, and propeller. Correct trim is also affected by variables such as the load in the boat, sea conditions, and running speed.

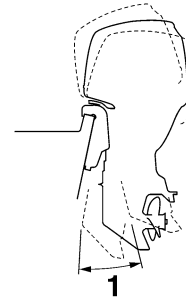

ZMU05170

1. Trim operating angle

EMU27889

Adjusting trim angle (Power trim and tilt)

EWMO0754

⚠ WARNING

- Be sure all people are clear of the outboard motor when adjusting the trim angle. Body parts can be crushed between the motor and the clamp bracket when the motor is trimmed or tilted.
- Use caution when trying a trim position for the first time. Increase speed gradually and watch for any signs of instability or control problems. Improper trim angle can cause loss of control.
- If equipped with a power trim and tilt switch located on the bottom cowling, use the switch only when the boat is at a complete stop with the engine off. Do not adjust the trim angle with this switch while the boat is moving.

Adjust the outboard motor trim angle using the power trim and tilt switch.

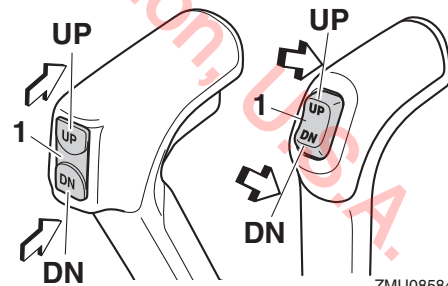

ZMU08584

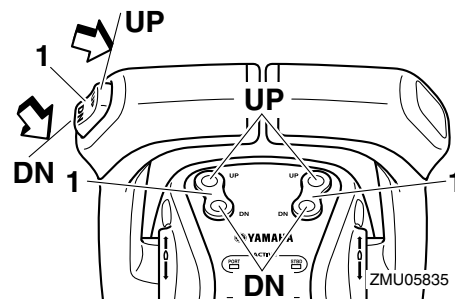

ZMU05835

Operation

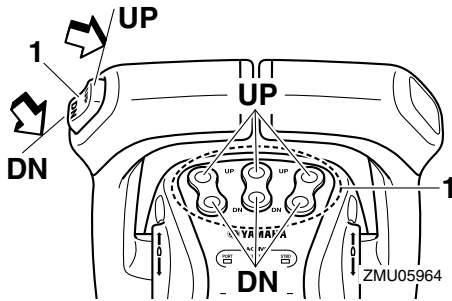

1. Power trim and tilt switch

To raise the bow (trim-out), press the switch “UP” (up). To lower the bow (trim-in), press the switch “DN” (down). Make test runs with the trim set to different angles to find the position that works best for your boat and operating conditions.

EMU27913

Adjusting boat trim

When the boat is on plane, a bow-up attitude results in less drag, greater stability and efficiency. This is generally when the keel line of the boat is up about 3 to 5 degrees. With the bow up, the boat may have a greater tendency to steer to one side or the other. Compensate for this as you steer. When the bow of the boat is down, it is easier to accelerate from a standing start onto plane.

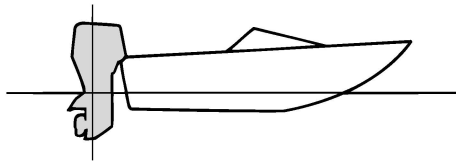

ZMU01784

Bow Up

Too much trim-out puts the bow of the boat too high in the water. Performance and economy are decreased because the hull of the boat is pushing the water and there is more air drag. Excessive trim-out can also cause the propeller to ventilate, which reduces performance further, and the boat may “porpoise” (hop in the water), which could throw the operator and passengers overboard.

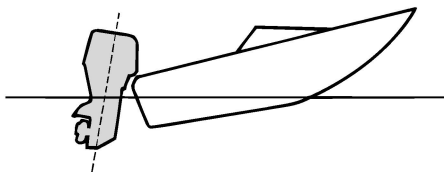

ZMU01785

Bow Down

Too much trim-in causes the boat to “plow” through the water, decreasing fuel economy and making it hard to increase

speed. Operating with excessive trim-in at higher speeds also makes the boat unstable. Resistance at the bow is greatly increased, heightening the danger of “bow steering” and making operation difficult and dangerous.

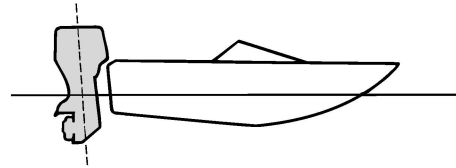

ZMU01786

TIP:

Depending on the type of boat, the outboard motor trim angle may have little effect on the trim of the boat when operating.

EMU27948

Tilting up and down

If the engine will be stopped for some time or if the boat is moored in shallows, the outboard motor should be tilted up to protect the propeller and lower case from damage by collision with obstructions, and also to reduce salt corrosion.

EWM01544

WARNING

Make sure that all people are clear of the outboard motor when tilting the outboard motor up and down. Body parts can be crushed between the outboard motor and the clamp bracket when the outboard motor is trimmed or tilted.

ECM00993

NOTICE

- Before tilting the outboard motor, follow the procedure under “Stopping engine” in this chapter. Never tilt the outboard motor while the engine is running. Severe damage from overheating can result.
- To prevent the cooling water passages from becoming frozen when the ambient temperature is 5°C (41°F) or below, tilt the outboard motor up after it has been stopped 30 seconds or more.

EMU3550B

Procedure for tilting up (power trim and tilt models)

1. Place the control lever in neutral.

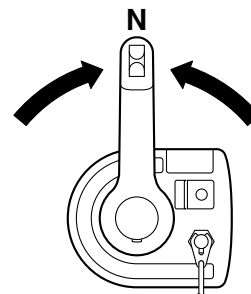

ZMU06236

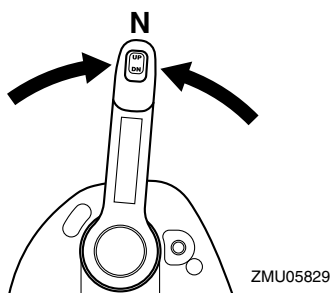

- Press the power trim and tilt switch “UP” (up) until the outboard motor has tilted up completely.

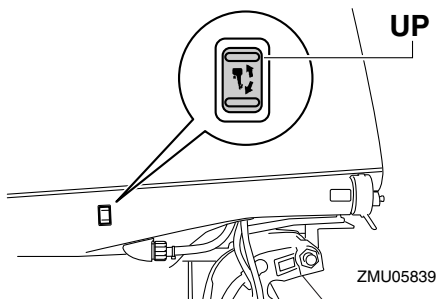
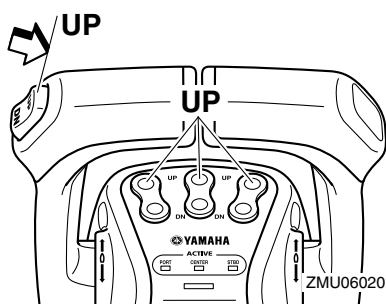
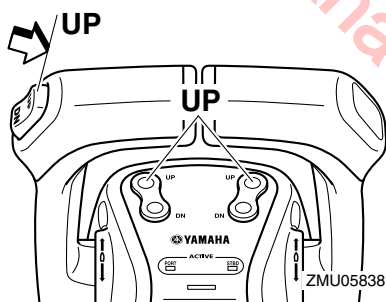
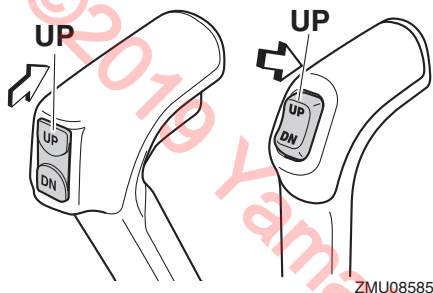

- Set the tilt support lever to support the engine. **WARNING! After tilting the outboard motor, be sure to support it with the tilt support knob or tilt support lever. Otherwise the outboard motor could fall back down suddenly if oil in the power trim and tilt**

unit or in the power tilt unit loses pressure. [EWM00263]
NOTICE: Do not use the tilt support lever or knob when trailering the boat. The outboard motor could shake loose from the tilt support and fall. If the motor cannot be trailered in the normal running position, use an additional support device to secure it in the tilt position. For more detailed information, see page 61. [ECM01642]

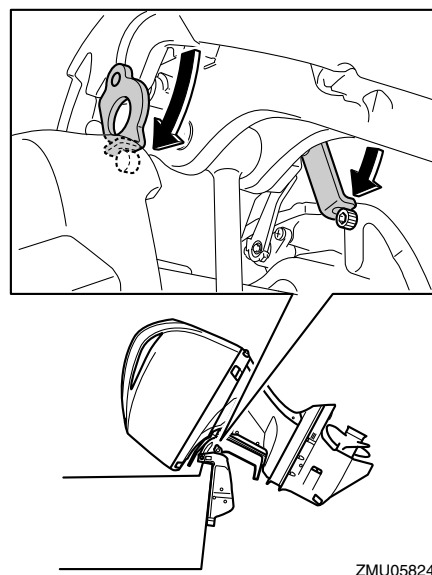

- Once the outboard motor is supported with the tilt support lever, press the power trim and tilt switch “DN” (down) to retract the trim rods. **NOTICE: Make sure that the trim rods retract completely during mooring. This protects the rods from marine growth and corrosion, which could damage the power trim and tilt mechanism.** [ECM00253]

EMU35517

Procedure for tilting down (power trim and tilt models)

- Push the power trim and tilt switch “UP” (up) until the outboard motor is supported by the tilt rod and the tilt support lever becomes free.
- Release the tilt support lever.

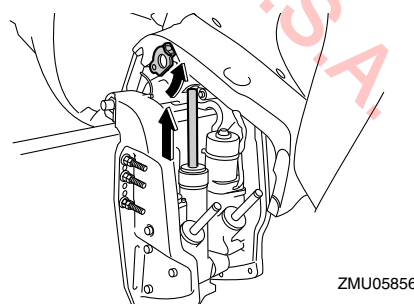

- Push the power trim and tilt switch “DN” (down) to lower the outboard motor to the desired position.

Operation

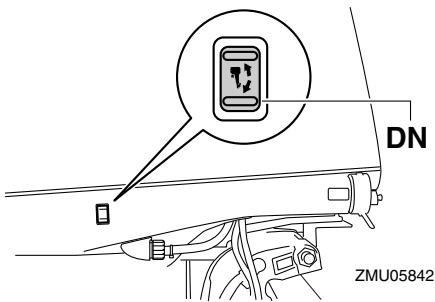
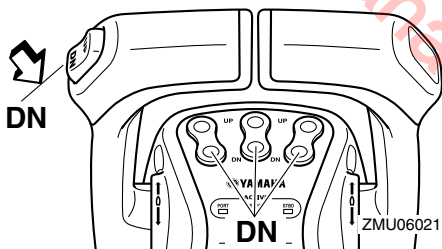
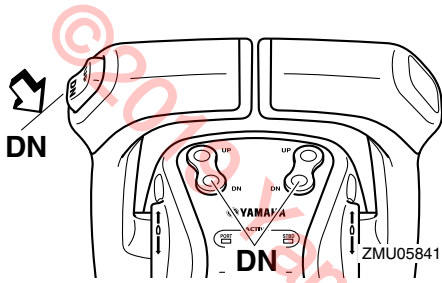
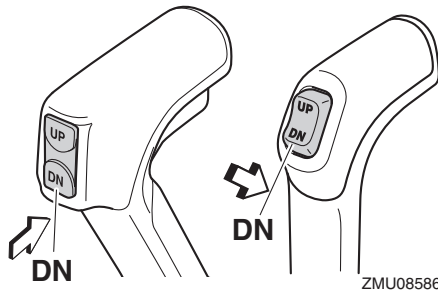

EMU28063

Shallow water

EMU42221

Power trim and tilt models

The outboard motor can be tilted up partially to allow operation in shallow water.

ECM01491

NOTICE

- If the engine speed is suddenly increased when the outboard motor is partially tilted up, the power trim and tilt unit could be damaged.
- Do not tilt the outboard motor up so that the cooling water inlet on the lower unit is above the surface of the water when setting up for and cruising in shallow water. Otherwise severe damage from overheating can result.

TIP:

When the outboard motor is partially tilted up for shallow water operation, the engine speed may be controlled around 2500 r/min. This occurs due to protect the power trim and tilt unit and does not indicate a malfunction. For instructions on de-activating the engine speed control system, see page 60.

EMU35237

Procedure for power trim and tilt models

1. Place the control lever in neutral.

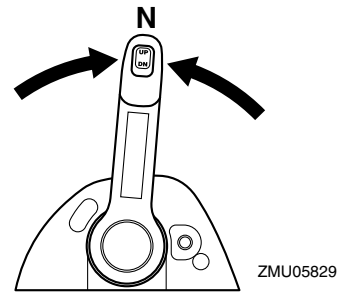
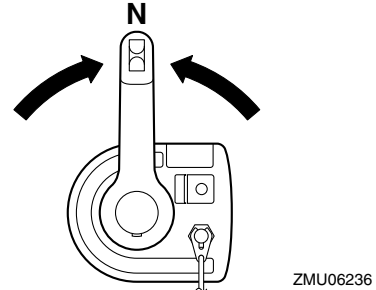

2. Slightly tilt the outboard motor up to the desired position using the power trim and tilt switch. **WARNING! Using the power trim and tilt switch on the bottom cowling while the boat is moving or engine is on could increase the risk of falling overboard and could distract the operator, increasing the risk of collision with another boat or an obstacle.** [EWM01851]

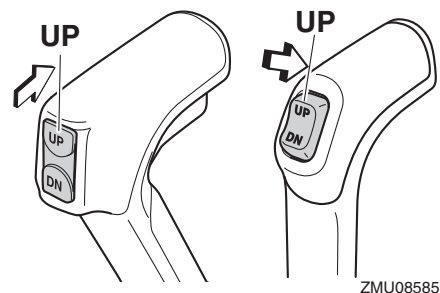
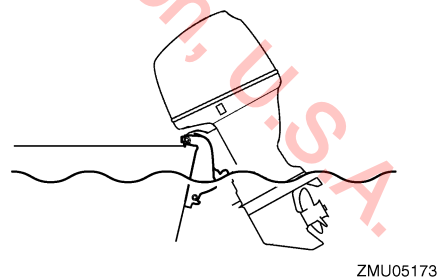

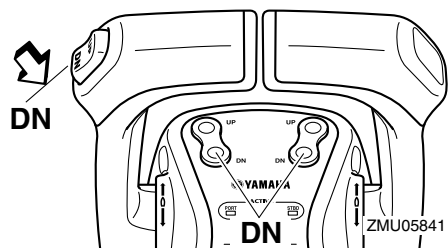
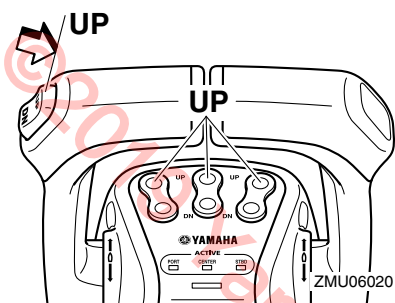
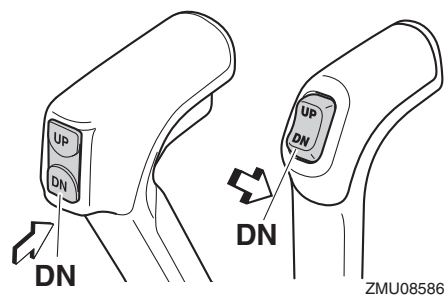
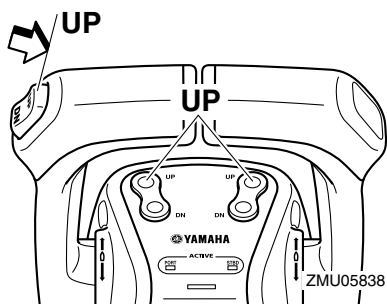

3. To return the outboard motor to the normal running position, press the power trim and tilt switch and slowly tilt the outboard motor down.

EMU42232

De-activating the engine speed control system

ECM02501

NOTICE

This procedure must be done out of the shallow water. Otherwise, the outboard motor may hit an object in the water as tilting down.

1. Close the throttle so that the engine slows to idle speed.
2. After the engine is at idle speed in gear move the control lever firmly and crisply into the neutral position.

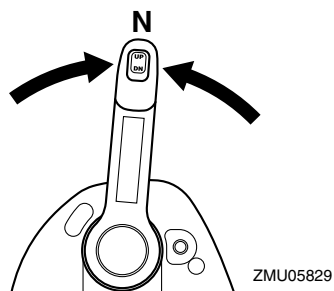
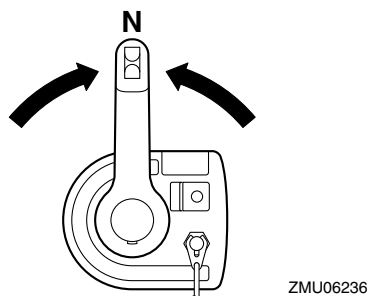

3. Press the power trim and tilt switch and tilt the outboard motor fully down.

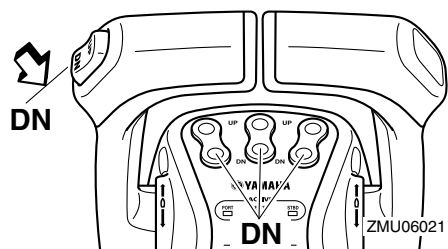

EMU41371

Operating in other conditions

Operating in salt water

After operating in saltwater, brackish water, or water high in other minerals, flush the cooling system with fresh water to minimize corrosion and clogging of the cooling water passages with deposits. Also, rinse the exterior of the outboard motor with fresh water.

Operating in water containing mud, sand, silt, debris, or vegetation

Mud, sand, silt, debris, and vegetation in the water may restrict water flow into the cooling water inlet covers or clog internal water passages. Check and clean the cooling water inlet covers frequently when operating in these conditions. Flush the engine with clean, fresh water after use in these environments. Consult your dealer if normal water flow can not be restored by cleaning the cooling water inlet covers or flushing with fresh water.

Maintenance

EMU41532

Transporting and storing outboard motor

EWM02641

⚠ WARNING

- **USE CARE** when transporting fuel tank, whether in a boat or car.
- **DO NOT** fill fuel container to maximum capacity. Gasoline will expand considerably as it warms up and can build up pressure in the fuel container. This can cause fuel leakage and a potential fire hazard.
- **Leaking fuel is a fire hazard.** Tighten securely the fuel valve when transporting and storing the outboard motor.
- **Never get under the outboard motor while it is tilted.** Severe injury could occur if the outboard motor accidentally falls.
- **Do not use the tilt support lever or knob when trailering the boat.** The outboard motor could shake loose from the tilt support and fall. If the outboard motor cannot be trailered in the normal running position, use an additional support device to secure it in the tilt position.

Leaking fuel is a fire hazard. When trailering the boat, close the fuel valve to prevent fuel from leaking.

The outboard motor should be transported and stored in the normal running position. If there is insufficient road clearance in this position, then trailer the outboard motor in the tilt position using a motor support device such as a transom saver bar. Consult your Yamaha dealer for further details. When the outboard motor is tilted prolonged time for mooring or trailering the boat, close the fuel valve.

EMU35412

Storing outboard motor

When storing your Yamaha outboard motor for prolonged periods of time (2 months or longer), several important procedures must be performed to prevent excessive damage. It is advisable to have your outboard motor serviced by an authorized Yamaha dealer prior to storage. However, you, the owner, with a minimum of tools, can perform the following procedures.

ECM01721

NOTICE

Store the outboard motor in a dry, well-ventilated place, not in direct sunlight.

Keep the outboard motor in the attitude shown when transporting and storing it.

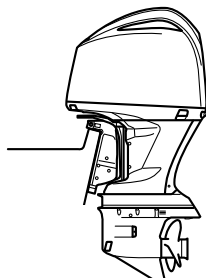

ZMU05843

EMU41382

Conditioning and stabilizing gasoline

When preparing to store a boat for extended periods (2 months or longer) it is best to completely remove all gasoline from the boat's fuel tank(s). If it is not possible to remove the gasoline, add one ounce of "Yamalube Fuel Stabilizer & Conditioner Plus" to each gallon of gasoline in a full tank of gasoline to provide fuel stability and corrosion protection.

TIP:

Do not fill the fuel tank(s) to the point of overflowing. Approximately 7/8 full will allow enough space in the fuel tank to prevent gasoline purging from the fuel tank vent due to expansion with temperature changes.

Do not cap the fuel tank vent. Excessive pressure could damage the boat and motor's fuel systems.

A partially filled fuel tank, less than 7/8 full but not completely empty, is not recommended. Air space above the gasoline allows air movement which can bring in water through condensation as the air temperature changes.

Condensation inside the fuel tank can cause corrosion problems and phase separation of gasoline containing ethanol.

Consult your Yamaha dealer concerning preventative measures that may work best for the gasoline and environmental conditions in your area.

EMU28306

Procedure

EMU41142

Cleaning the outboard motor

When cleaning the outboard motor, the top cowling must be installed.

1. Wash the exterior of the outboard motor using fresh water. **NOTICE: Do not spray water into the air intake.**

[ECM01841]

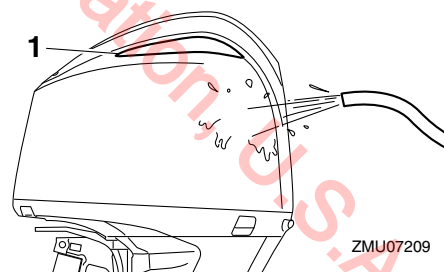

ZMU07209

1. Air intake
2. Drain the cooling water completely out of the outboard motor. Clean the body thoroughly.

EMU41072

Lubrication

1. Change the gear oil. For instructions, see page 69. Check the gear oil for the presence of water that indicates a leaky seal. Seal replacement should be performed by an authorized Yamaha dealer prior to use.
2. Lubricate all grease fittings. For further details, see page 66.

TIP:

For long-term storage, fogging the engine with fogging oil is

recommended. Contact your Yamaha dealer for information about fogging oil and procedures for your outboard motor.

EMU41153

Cleaning and anticorrosion measures

1. Wash the exterior of the outboard motor using fresh water, and then dry the outboard motor completely. For instructions on cleaning the outboard motor, see page 61. **NOTICE: Do not spray water into the air intake.**

[ECM01841]

2. Spray the outboard motor powerhead with “Yamaha Silicone Protectant.”
3. Wax the cowling with a non-abrasive wax such as “Yamaha Silicone Wax.”

EMU28446

Flushing power unit

Perform this procedure right after operation for the most thorough flushing.

ECM01531

NOTICE

Do not perform this procedure while the engine is running. The water pump may be damaged and severe damage from overheating can result.

1. After shutting off the engine, unscrew the garden hose connector from the fitting on the bottom cowling.

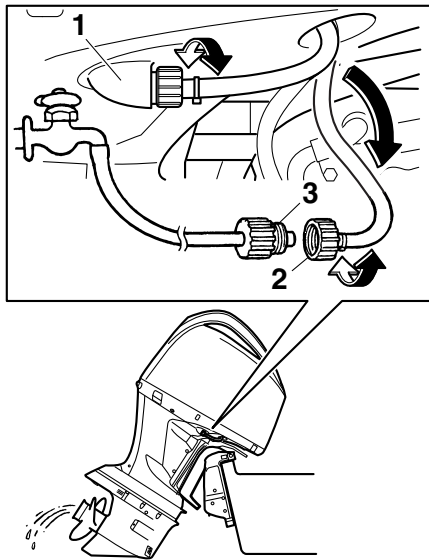

ZMU05844

1. Fitting
 2. Garden hose connector
 3. Garden hose adapter
2. Screw the garden hose adapter onto a garden hose, which is connected to a fresh water supply, and then connect it to the garden hose connector.
 3. With the engine off, turn on the water tap and let the water flush through the cooling passages for about 15 minutes. Turn off the water and disconnect the garden hose adapter from the garden hose connector.
 4. Reinstall the garden hose connector onto the fitting on the bottom cowling. Tighten the connector securely. **NOTICE: Do not leave the garden hose connector**

loose on the bottom cowling fitting or let the hose hang free during normal operation. Water will leak out of the connector instead of cooling the engine, which can cause serious overheating. Be sure the connector is tightened securely on the fitting after flushing the engine. [ECM00542]

TIP:

- When flushing the engine with the boat in the water, tilting up the outboard motor until it is completely out of the water will achieve better results.
- For cooling system flushing instructions, see page 61.

EMU28463

Checking painted surface of outboard motor

Check the outboard motor for scratches, nicks, or flaking paint. Areas with damaged paint are more likely to corrode. If necessary, clean and paint the areas. Touch-up paint is available from your Yamaha dealer.

EMU2846D

Periodic maintenance

EWM01872

WARNING

These procedures require mechanical skills, tools, and supplies. If you do not have the proper skills, tools, or supplies to perform a maintenance procedure, have a Yamaha dealer or other qualified mechanic do the work. The procedures involve disassembling the motor and exposing dangerous parts. To reduce the risk of injury from moving, hot, or electrical parts:

- Turn off the engine and keep the key(s) and engine shut-off cord (lanyard) with you when you perform maintenance unless otherwise specified.
- The power trim and tilt switches operate even when the ignition key is off. Keep people away from the switches whenever working around the motor. When the motor is tilted, keep away from the area under it or between it and the clamp bracket. Be sure no one is in this area before operating the power trim and tilt mechanism.
- Allow the engine to cool before handling hot parts or fluids.
- Always completely reassemble the motor before operation.

Maintenance, replacement, or repair of the emission control devices and systems may be performed by any marine engine repair establishment or individual. All warranty repairs, however, including those to the emission control system, must be performed by an authorized Yamaha marine dealership.

A service manual is available for purchase through your Yamaha dealer for owners who have the mechanical skills, tools, and other equipment necessary to perform maintenance not covered by this owner's manual.

EMU28512

Replacement parts

If replacement parts are necessary, use only genuine Yamaha parts or parts of equivalent design and quality. Any part of inferior quality may malfunction, and the resulting loss of control could endanger the operator and passen-

Maintenance

gers. Yamaha genuine parts and accessories are available from your Yamaha dealer.

EMU35522

Maintenance interval guidelines

The service intervals provided in the Maintenance Chart were developed based upon "typical" use that includes operating at varied speeds, with sufficient time for engine warm up and cool-down, a medium to light load, and an average cruising speed near the 3000 to 4000 rpm range. As with any engine, however, if your normal operating conditions are different, you should consider service more often than shown, especially how often you change your engine oil and gear oil. Examples might include extended wide-open-throttle use or long periods of trolling or idling, carrying heavy loads, or frequent starting and stopping or shifting. More frequent maintenance will often pay off many times over in increased engine life and greater owner satisfaction. Consult your Yamaha dealer for additional maintenance recommendations.

© 2019 Yamaha Motor Corporation, U.S.A.

EMU46890

Maintenance chart 1

TIP:

- Refer to the sections in this chapter for explanations of each owner-specific action.
- The maintenance cycle on these charts assume usage of 100 hours per year and regular flushing of the cooling water passages. Maintenance frequency should be adjusted when operating the engine under adverse conditions such as extended trolling.
- Disassembly or repairs may be necessary depending on the outcome of maintenance checks.
- Expendable or consumable parts and lubricants will lose their effectiveness over time and through normal usage regardless of the warranty period.
- When operating in salt water, muddy, other turbid (cloudy), acidic water, the engine should be flushed with clean water after each use.

The “●” symbol indicates the check-ups which you may carry out yourself.

The “○” symbol indicates work to be carried out by your Yamaha dealer.

Item	Actions	Initial	Every			Page
		20 hours (3 months)	100 hours (1 year)	300 hours (3 years)	500 hours (5 years)	
Anode(s) (external)	Inspection or replacement as necessary		●/○			70
Anode(s) (internal) *1	Inspection or replacement as necessary		○			—
Anode(s) (internal) *2	Replacement				○	—
Battery (electrolyte level, terminal)	Inspection	●/○	●/○			71
Battery (electrolyte level, terminal)	Fill, charging or replacing as necessary		○			—
Cooling water leakage	Inspection or replacement as necessary	○	○			—
Cowling lock lever	Inspection		●/○			41, 43
Engine starting condition/noise	Inspection	●/○	●/○			45
Engine idle speed/noise	Inspection	●/○	●/○			67
Engine oil	Replacement	○	○			—
Engine oil filter (cartridge)	Replacement		○			—
Fuel filter (can be disassembled)	Inspection or replacement as necessary	●/○	●/○			42
Fuel line (High pressure)	Inspection	●	●			—
Fuel line (High pressure)	Inspection or replacement as necessary	○	○			—
Fuel line (Low pressure)	Inspection	●	●			—
Fuel line (Low pressure)	Inspection or replacement as necessary	○	○			—
Fuel pump	Inspection or replacement as necessary			○		—
Fuel/engine oil leakage	Inspection	○	○			—
Gear oil	Replacement	●/○	●/○			69
Greasing points	Greasing	●/○	●/○			66
Clamp bracket bolt (through tube)	Inspection and greasing		○			—
Impeller/water pump housing	Inspection or replacement as necessary		○			—
Impeller/water pump housing	Replacement			○		—
OCV (Oil Control Valve) filter	Replacement				○	—
Power trim and tilt unit	Inspection	●/○	●/○			44
Propeller/propeller nut/cotter pin	Inspection or replacement as necessary	●/○	●/○			68

Maintenance

Item	Actions	Initial	Every			Page
		20 hours (3 months)	100 hours (1 year)	300 hours (3 years)	500 hours (5 years)	
PCV (Pressure Control Valve)	Inspection or replacement as necessary		○			—
Spark plug(s)	Inspection or replacement as necessary		●/○			66
Water from the cooling water pilot hole	Inspection	●/○	●/○			47
Thermostat	Inspection or replacement as necessary		○			—
Timing belt	Inspection or replacement as necessary		○			—
Valve clearance	Inspection and adjustment				○	—
Cooling water inlet	Inspection	●/○	●/○			18
Main switch/stop switch	Inspection or replacement as necessary	○	○			—
Wire harness connections/wire coupler connections	Inspection or replacement as necessary	○	○			—
(Yamaha) Meter/gauge	Inspection	○	○			—

EMU46260

*1 cylinder head, thermostat cover

*2 exhaust joint, cylinder block, crankcase cover, Rectifier Regulator cover, upper case

EMU46900

Maintenance chart 2

Item	Actions	Every	Page
		1000 hours	
Exhaust guide/exhaust manifold	Inspection or replacement as necessary	○	—
Timing belt	Replacement	○	—

EMU46910

Maintenance chart 3

TIP:

This outboard motor is equipped with a function that indicates when replacement of the flywheel magneto is due.

When replacement is due, the engine trouble-alert indicator activates or flashes.

Check the trouble codes, and if 87 is displayed on the meter, take it to a Yamaha dealer for a flywheel replacement at no charge.

Refer to the meter's operation manual on how to check the trouble codes.

Item	Actions	Every	Page
		Every time indicated on the meter	
Flywheel magneto	Replacement	○	—

EMU41302

Greasing

Yamalube Marine Grease

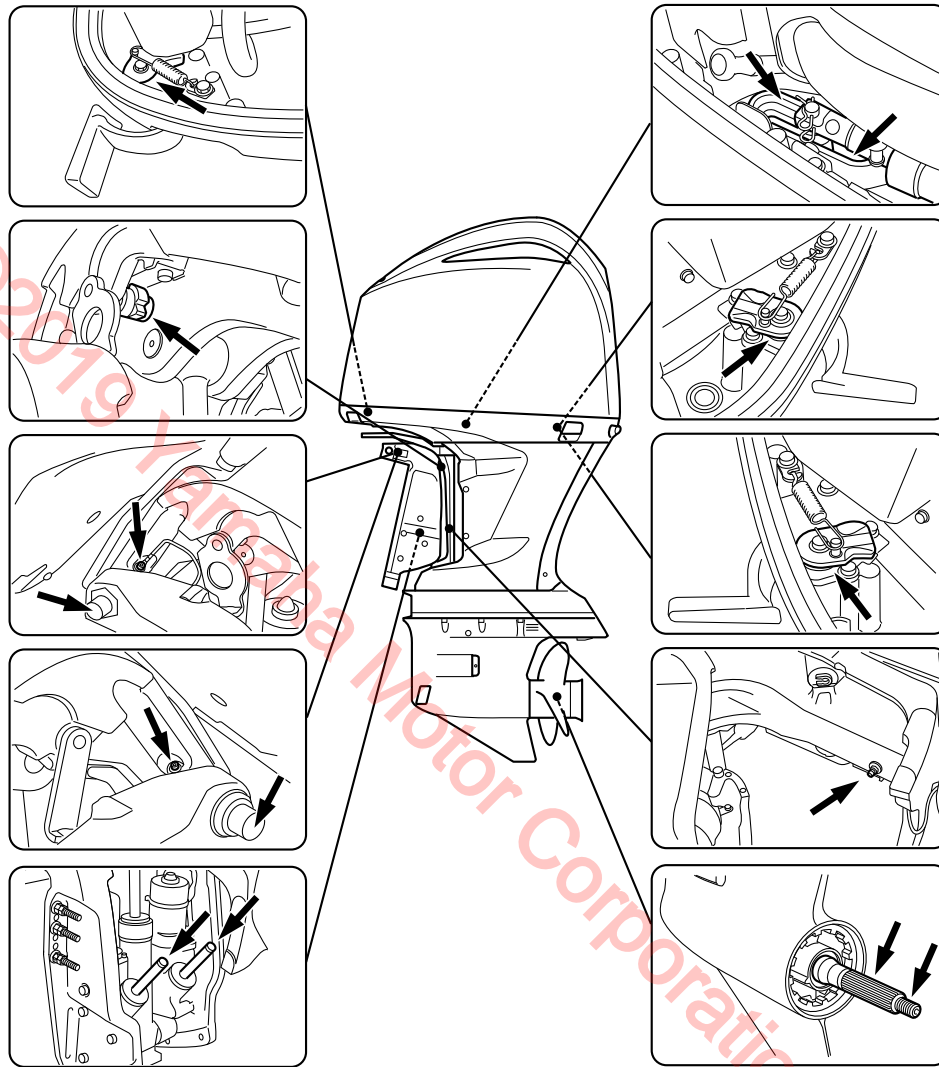

ZMU05859

EMU44282

Inspecting spark plug

The spark plug is an important engine component. The condition of the spark plug can indicate something about the condition of the engine. For example, if the center electrode porcelain is very white, this could indicate an intake air leak or carburetion problem in that cylinder. Do not attempt to diagnose any problems yourself. Instead, take the outboard motor to a Yamaha dealer. You should periodically remove and check the spark plug because heat and deposits will cause the spark plug to slowly break down and erode.

To remove the spark plug

1. Remove the covers of both port and starboard sides.

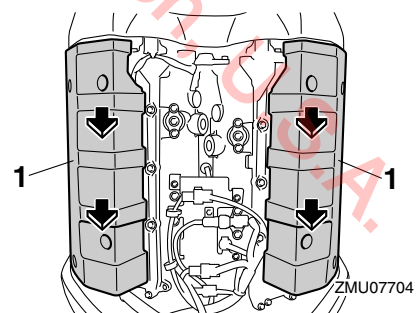

ZMU07704

1. Cover
2. Remove the bolt that is securing the ignition coil, and then remove the ignition coil. **NOTICE: Do not use any tools to remove or install the ignition coil. Otherwise, the ignition coil coupler could be damaged.**

[ECM02331]

Maintenance

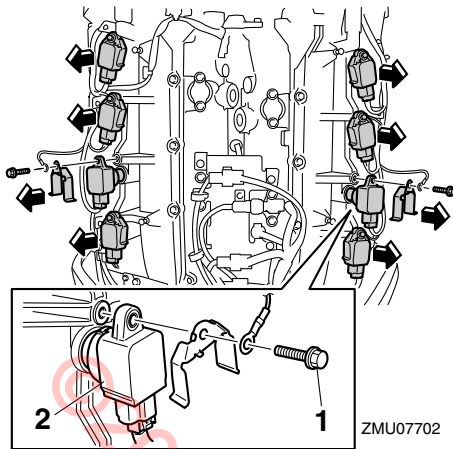

1. Bolt
2. Ignition coil

3. Remove the spark plug. **WARNING! When removing or installing a spark plug, be careful not to damage the insulator. A damaged insulator could allow external sparks, which could lead to explosion or fire.**

[EWM00562]

To check the spark plug

1. Check the condition of the spark plug. If electrode erosion becomes excessive or carbon and other deposits are excessive, replace the spark plug with the specified plug.

Standard spark plug:
LFR6A-11

2. Measure the spark plug gap using a thickness gauge. If the spark plug gap is out of specification, replace the spark plug with the specified plug.

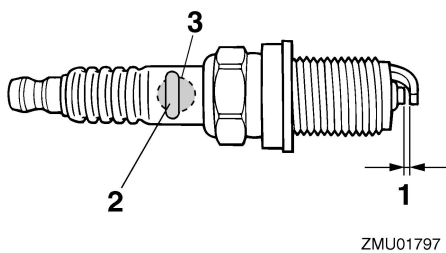

1. Spark plug gap
2. Spark plug part number
3. Spark plug I.D. mark (NGK)

Spark plug gap:
1.0–1.1 mm (0.039–0.043 in)

To install the spark plug

1. Wipe off any dirt from the threads, insulator, and gasket surface of the spark plug.
2. Install the spark plug, and then tighten it to the specified torque.

Spark plug tightening torque:
28 Nm (2.86 kgf-m, 20.7 ft-lb)

TIP:

If a torque-wrench is not available when you are reinstalling a spark plug, a good estimate of the correct torque is 1/12 turn past finger-tight. When you are installing a new spark plug, a good estimate of the correct torque is 1/2 to 2/3 turn past finger-tight.

3. Install the ignition coil, and then tighten the bolt to the specified torque.

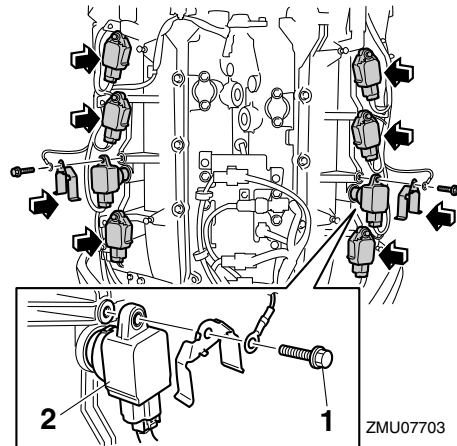

1. Bolt
2. Ignition coil

Bolt tightening torque:
9 Nm (0.92 kgf-m, 6.6 ft-lb)

4. Fit the four positions and install the covers of both port and starboard sides securely.

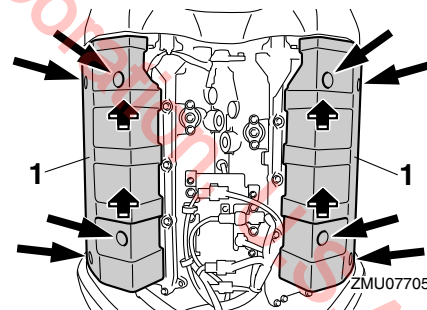

1. Cover

EMU41872

Inspecting engine idle speed

ECM01691

NOTICE

This procedure must be performed while the outboard motor is in the water.

Inspect the engine idle speed using the meter that is equipped on the boat. Results may vary depending on whether testing is conducted with the outboard motor in the water.

1. Start the engine and allow it to warm up fully in neutral until it is running smoothly.

- Inspect the engine idle speed. If the engine idle speed is out of specification, consult a Yamaha dealer or other qualified mechanic.

Idle speed (in neutral):
600–700 r/min

EMU35085

Changing engine oil

ECM01711

NOTICE

Change the engine oil after the first 20 hours of operation or 3 months, and every 100 hours or at 1-year intervals thereafter. Otherwise the engine will wear quickly.

Consult your Yamaha dealer for replacement of the engine oil filter and change of the engine oil.

EMU29116

Inspecting wiring and connectors

- Inspect that each connector is engaged securely.
- Inspect that each ground lead is properly secured.

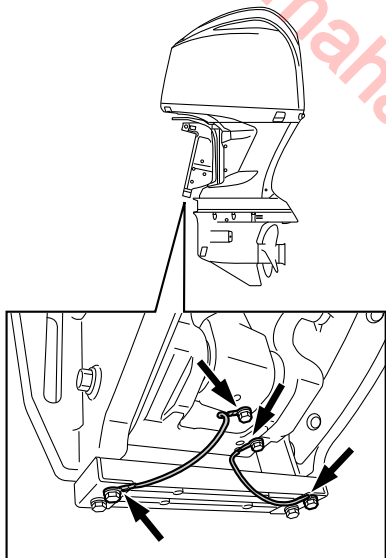

ZMU05867

EMU29175

Checking propeller

EWV01882

⚠ WARNING

You could be seriously injured if the engine accidentally starts when you are near the propeller. Before inspecting, removing, or installing the propeller, place the shift control in neutral, turn the main switch to "OFF" (off) and remove the key, and remove the clip from the engine shut-off switch. Turn off the battery cut-off switch if your boat has one.

Do not use your hand to hold the propeller when loosening or tightening the propeller nut. Put a wood block between the anti-cavitation plate and the propeller to prevent the propeller from turning.

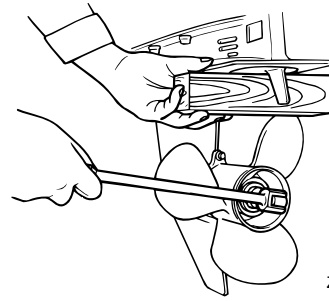

ZMU01897

Checkpoints

- Check each of the propeller blades for erosion from cavitation or ventilation, or other damage.
- Check the propeller shaft for damage.
- Check the splines for wear or damage.
- Check for fish line tangled around the propeller shaft.

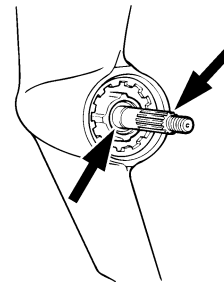

ZMU01803

- Check the propeller shaft oil seal for damage.

EMU30663

Removing propeller

EMU29198

Spline models

- Straighten the cotter pin and pull it out using a pair of pliers.
- Remove the propeller nut, washer, and spacer (if equipped). **WARNING! Do not use your hand to hold the propeller when loosening the propeller nut.**

[EWM01891]

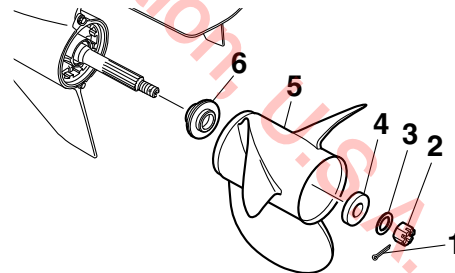

ZMU07268

- Cotter pin
 - Propeller nut
 - Washer
 - Spacer
 - Propeller
 - Thrust washer
- Remove the propeller, washer (if equipped), and thrust washer.

Maintenance

EMU30673

Installing propeller

EMU29247

Spline models

EWM00771

⚠ WARNING

On counter rotation models, be sure to use a propeller intended for counterclockwise rotation. These propellers are identified with the letter "L" after the size indication on the propeller. Otherwise the boat could move in the opposite direction from that expected.

ECM00502

NOTICE

Make sure to use a new cotter pin and bend the ends over securely. Otherwise, the propeller could come off during operation and be lost.

1. Apply Yamalube Marine Grease or a corrosion resistant grease to the propeller shaft.
2. Install the thrust washer and propeller on the propeller shaft. **NOTICE: Make sure to install the thrust washer before installing the propeller. Otherwise, the lower case and propeller boss could be damaged.**

[ECM01882]

3. Install the spacer and washer. Tighten the propeller nut to the specified torque.

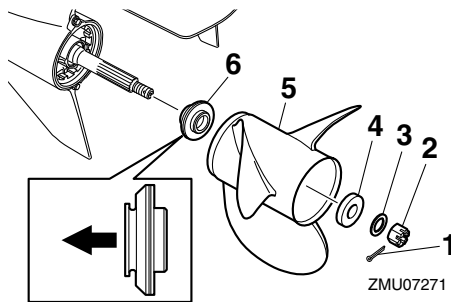

1. Cotter pin
2. Propeller nut
3. Washer
4. Spacer
5. Propeller
6. Thrust washer

Propeller nut tightening torque:
54 Nm (5.51 kgf-m, 39.8 ft-lb)

4. Align the propeller nut slot with the propeller shaft hole. Insert a new cotter pin in the hole and bend the cotter pin ends. **NOTICE: Do not reuse the cotter pin. Otherwise, the propeller can come off during operation.** [ECM01892]

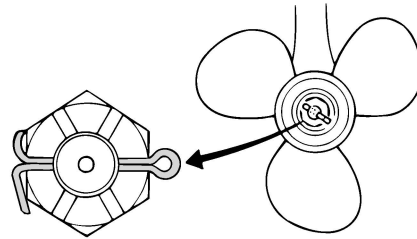

ZMU01805

TIP:

If the propeller nut slot does not align with the propeller shaft hole after tightening the propeller nut to the specified torque, tighten the nut further to align the slot with the hole.

EMU31918

Changing gear oil

EWM00801

⚠ WARNING

- Be sure the outboard motor is securely fastened to the transom or a stable stand. You could be severely injured if the outboard motor falls on you.
- Never get under the lower unit while it is tilted, even when the tilt support lever or knob is locked. Severe injury could occur if the outboard motor accidentally falls.

1. Tilt the outboard motor so that the gear oil drain screw is at the lowest point possible.
2. Place a suitable container under the gear case.
3. Remove the cooling water inlet covers on both sides of the gear case. Be careful not to lose the bolt and nut.
4. Remove the gear oil drain screw and gasket. The screw is magnetic so a small quantity of metal particles on the end of the screw is normal. Simply remove them.

NOTICE: If there is an excessive quantity of metal particles on the magnetic gear oil drain screw, this can indicate lower unit problem. Consult your Yamaha dealer. [ECM01901]

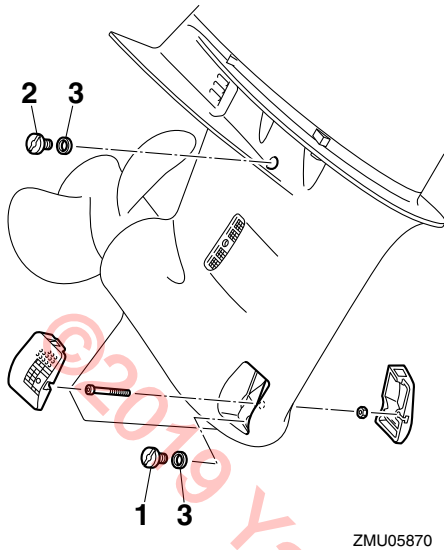

1. Gear oil drain screw
2. Oil level plug
3. Gasket

5. Remove the oil level plug and gasket to allow the oil to drain completely. **NOTICE: Check the used gear oil after it has been drained. If the gear oil is milky or contains water or a large amount of metal particles, the gear case may be damaged. Have a Yamaha dealer check and repair the outboard motor.** [ECM00714]

TIP:

For disposal of used oil, consult your Yamaha dealer.

6. Put the outboard motor in a vertical position. Using a flexible or pressurized filling device, inject the gear oil into the gear oil drain screw hole.

Recommended gear oil:

Yamalube Marine Gearcase Lube HD or Hypoid gear oil

Recommended gear oil grade:

SAE 80W API GL-5 / SAE 90 API GL-5

Gear oil quantity:

1.310 L (1.385 US qt, 1.153 Imp.qt) (LF350CC)
 1.520 L (1.607 US qt, 1.338 Imp.qt) (F350CC)

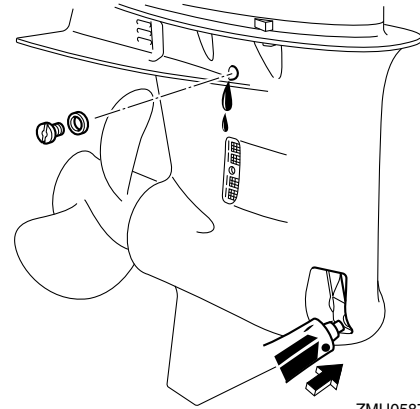

7. Put a new gasket on the oil level plug. When the oil begins to flow out of the oil level plug hole, insert and tighten the oil level plug.

Tightening torque:

7 Nm (0.71 kgf-m, 5.2 ft-lb)

8. Put a new gasket on the gear oil drain screw. Insert and tighten the gear oil drain screw.

Tightening torque:

7 Nm (0.71 kgf-m, 5.2 ft-lb)

9. Securely install the cooling water inlet covers on both sides of the gear case using the bolt and nut removed earlier.

Tightening torque:

2.0 Nm (0.20 kgf-m, 1.5 ft-lb)

EMU29318

Inspecting and replacing anode(s)

Yamaha outboard motors are protected from corrosion by sacrificial anodes. Inspect the external anodes periodically. Remove scales from the surfaces of the anodes. Consult a Yamaha dealer for replacement of external anodes.

ECM00721

NOTICE

Do not paint anodes, as this would render them ineffective.

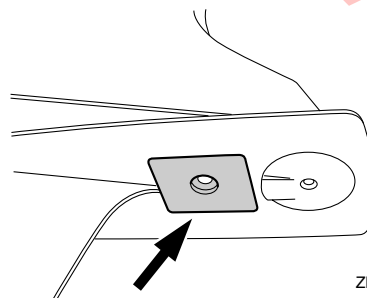

ZMU05872

Maintenance

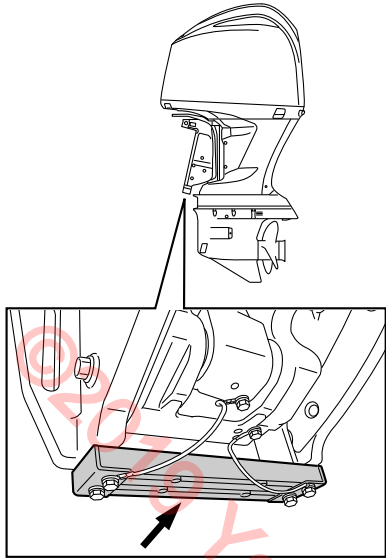

ZMU05873

TIP:

Inspect ground leads attached to external anodes on equipped models. Consult a Yamaha dealer for inspection and replacement of internal anodes attached to the power unit.

EMU29324

Checking battery (for electric start models)

EWM01903

WARNING

Battery electrolyte is poisonous and caustic, and batteries generate explosive hydrogen gas. When working near the battery:

- Wear protective eye gear and rubber gloves.
- Do not smoke or bring any other source of ignition near the battery.

The procedure for checking the battery varies for different batteries. This procedure contains typical checks that apply to many batteries, but you should always refer to the battery manufacturer's instructions.

ECM01921

NOTICE

A poorly maintained battery will quickly deteriorate.

1. Check the electrolyte level.

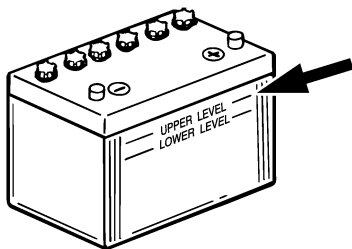

ZMU01810

2. Check the battery's charge. If your boat is equipped with the digital speedometer, the voltmeter and low battery alert functions will help you monitor the battery's charge. If the battery needs charging, consult your

Yamaha dealer.

3. Check the battery connections. They should be clean, secure, and covered by an insulating cover.
WARNING! Bad connections can produce shorting or arcing and cause an explosion. [EWM01913]

EMU42331

Connecting the battery

EWM00573

WARNING

Mount the battery holder securely in a dry, well-ventilated, vibration-free location in the boat. Install a fully charged battery in the holder.

ECM01125

NOTICE

Do not reverse the battery cables. Otherwise, the electrical parts could be damaged.

1. Make sure the main switch (on applicable models) is "OFF" (off) before working on the battery.
2. Connect the red battery cable to the POSITIVE (+) terminal first. Then connect the black battery cable to the NEGATIVE (-) terminal.

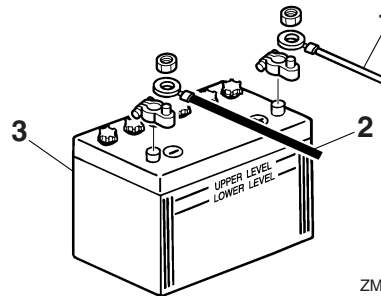

ZMU01811

1. Red cable
2. Black cable
3. Battery

3. The electrical contacts of the battery and cables must be clean and properly connected, or the battery will not start the engine.

Connecting an accessory battery (optional)

If connecting an accessory battery, consult your Yamaha dealer about correct wiring. For the fuse size, see ABYC (E-11).

Single engine

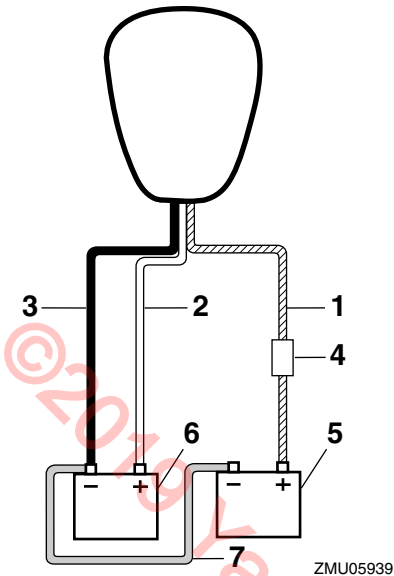

1. Isolator lead with circuit protection
2. Red cable
3. Black cable
4. Fuse
5. Battery for accessories
6. Battery for starting
7. Negative connecting cable

Triple engines

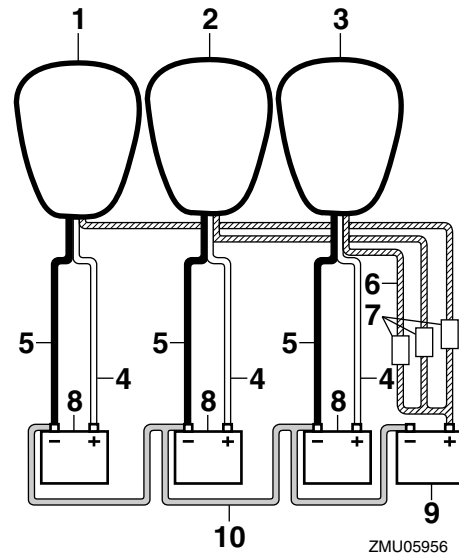

1. Starboard side engine
2. Center engine
3. Port side engine
4. Red cable
5. Black cable
6. Isolator lead with circuit protection
7. Fuse
8. Battery for starting
9. Battery for accessories
10. Negative connecting cable

Twin engines

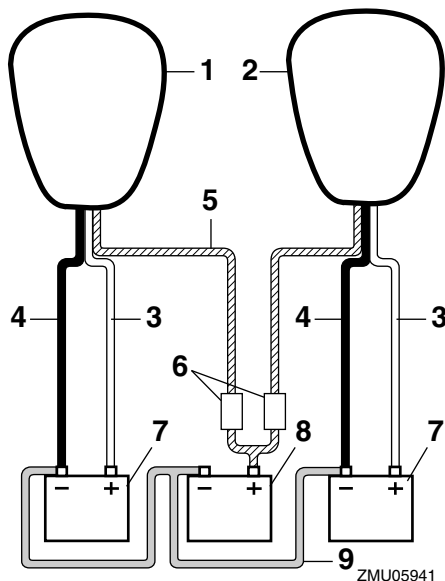

1. Starboard side engine
2. Port side engine
3. Red cable
4. Black cable
5. Isolator lead with circuit protection
6. Fuse
7. Battery for starting
8. Battery for accessories
9. Negative connecting cable

EMU29372

Disconnecting the battery

1. Turn off the battery cut-off switch (if equipped) and main switch. **NOTICE: If they are left on, the electrical system can be damaged.** [ECM01931]
2. Disconnect the negative cable(s) from the negative (-) terminal. **NOTICE: Always disconnect all negative (-) cables first to avoid a short circuit and damage to the electrical system.** [ECM01941]
3. Disconnect the positive cable(s) and remove the battery from the boat.
4. Clean, maintain, and store the battery according to the manufacturer's instructions.

EMU38661

Storing the battery

When storing your Yamaha outboard motor for prolonged periods of time (2 months or longer), remove the battery and store it in a cool, dry place.

Check the battery and charge it if necessary.

Trouble Recovery

EMU46920

Troubleshooting

This section describes the likely causes and remedies for problems, such as those in the fuel, compression, and ignition systems, poor starting, and loss of power. Please note that all of the items in this section may not apply to your model.

If your outboard motor requires repair, bring it to a Yamaha dealer.

If the engine trouble-alert indicator is blinking, consult your Yamaha dealer.

Trouble		
Starter will not operate.		
Item	Question	Answer
Digital electronic control-alert indicator	Does the Digital electronic control-alert indicator come on?	Have serviced by a Yamaha dealer.
Control lever	Is control lever in gear?	Shift to neutral.
Battery	Is battery capacity low or weak?	Check battery condition. Use battery of recommended capacity.
	Are battery connections corroded or loose?	Tighten battery cables and clean battery terminals.
Fuse	Is fuse for starter relay or electric circuit blown?	Check for cause of electric overload and repair. Replace fuse with one of correct amperage.
Starter	Are starter components malfunctioning?	Have serviced by a Yamaha dealer.

Trouble		
Engine will not start (starter operates).		
Item	Question	Answer
Engine shut-off cord (lanyard)	Is clip on engine shut-off cord (lanyard) installed?	Install clip to engine shut-off switch.
Fuel tank	Is fuel tank empty?	Fill tank with clean, fresh fuel.
Fuel	Is fuel contaminated or stale?	Fill tank with clean, fresh fuel.
Fuel filter	Is fuel filter clogged?	Clean or replace fuel filter.
Fuel pump	Is fuel pump malfunctioning?	Have serviced by a Yamaha dealer.
Spark plugs	Are spark plugs fouled or of incorrect type?	Inspect spark plugs. Clean or replace with recommended type.
Ignition parts	Are ignition parts malfunctioning?	Have serviced by a Yamaha dealer.
Ignition wiring	Is ignition wiring damaged or poorly connected?	Inspect wires for breaks and wear. Have connections tightened and broken or worn wires replaced by a Yamaha dealer.
Engine inner parts	Are engine inner parts damaged?	Have serviced by a Yamaha dealer.

Trouble		
Engine idles irregularly or stalls.		
Item	Question	Answer
Spark plugs	Are spark plugs fouled or of incorrect type?	Inspect spark plugs. Clean or replace with recommended type.
	Is spark plug gap incorrect?	Replace spark plug.
Fuel system	Is fuel system clogged?	Inspect for pinched or kinked fuel line or other obstructions in fuel system.
Fuel	Is fuel contaminated or stale?	Fill tank with clean, fresh fuel.
Fuel filter	Is fuel filter clogged?	Clean or replace fuel filter.
Ignition parts	Are ignition parts malfunctioning?	Have serviced by a Yamaha dealer.
Alert system	Has alert system activated?	Find and correct cause of alert.
Ignition wiring	Is ignition wiring damaged or poorly connected?	Inspect wires for breaks and wear. Have connections tightened and broken or worn wires replaced by a Yamaha dealer.
Engine oil	Is specified engine oil not being used?	Inspect engine oil and replace with specified type.
Thermostat	Is thermostat clogged or malfunctioning?	Have serviced by a Yamaha dealer.
Fuel pump	Is fuel pump malfunctioning?	Have serviced by a Yamaha dealer.
Fuel tank	Is fuel tank air vent restricted or clogged?	Remove obstruction.
Fuel joint	Is fuel joint connection incorrect?	Connect correctly.
Battery	Is battery cable disconnected?	Connect securely.

Trouble Recovery

Trouble	Alert buzzer sounds or indicator lights.	
Item	Question	Answer
Cooling system	Is cooling system clogged?	Inspect cooling water inlet for obstructions.
Low oil pressure-alert	Is low oil pressure-alert indicator on or blinking?	Have serviced by a Yamaha dealer.
Spark plugs	Is heat range of spark plugs incorrect?	Inspect spark plugs and replace with recommended type.
Engine oil	Is specified engine oil not being used?	Inspect engine oil and replace with specified type.
	Is engine oil contaminated or deteriorated?	Replace engine oil with specified type.
Oil filter	Is oil filter clogged?	Have serviced by a Yamaha dealer.
Oil pump	Is oil pump malfunctioning?	Have serviced by a Yamaha dealer.
Thermostat	Is thermostat malfunctioning?	Have serviced by a Yamaha dealer.
Water pump	Is water pump malfunctioning?	Have serviced by a Yamaha dealer.
Fuel filter	Is there excess water in fuel filter?	Drain fuel filter.

Trouble	Engine power loss.	
Item	Question	Answer
Propeller	Is propeller damaged?	Have propeller repaired or replaced.
	Is propeller pitch or diameter incorrect?	Install correct propeller to operate outboard motor at its recommended speed (r/min) range.
Mounting height	Is outboard motor mounted at incorrect height on transom?	Have outboard motor adjusted to proper transom height.
Alert system	Has alert system activated?	Find and correct cause of alert.
Boat bottom	Is boat bottom fouled with marine growth?	Clean boat bottom.
Spark plugs	Are spark plugs fouled or of incorrect type?	Inspect spark plugs. Clean or replace with recommended type.
	Is spark plug gap incorrect?	Replace spark plug.
	Is heat range of spark plugs incorrect?	Inspect spark plugs and replace with recommended type.
Lower unit	Are weeds or other foreign material tangled on gear housing?	Remove foreign material and clean lower unit.
Fuel system	Is fuel system clogged?	Inspect for pinched or kinked fuel line or other obstructions in fuel system.
Fuel filter	Is fuel filter clogged?	Clean or replace fuel filter.
Fuel	Is fuel contaminated or stale?	Fill tank with clean, fresh fuel.
	Is specified fuel not being used?	Replace fuel with specified type
Ignition wiring	Is ignition wiring damaged or poorly connected?	Inspect wires for breaks and wear. Have connections tightened and broken or worn wires replaced by a Yamaha dealer.
Electrical parts	Are electrical parts malfunctioning?	Have serviced by a Yamaha dealer.
Engine oil	Is specified engine oil not being used?	Replace engine oil with specified type.
Thermostat	Is thermostat clogged or malfunctioning?	Have serviced by a Yamaha dealer.
Fuel tank	Is fuel tank air vent restricted or clogged?	Remove obstruction.
Fuel pump	Is fuel pump malfunctioning?	Have serviced by a Yamaha dealer.
Fuel joint	Is fuel joint connection incorrect?	Connect correctly.
Control lever	Is engine not responding properly to control lever position?	Have serviced by a Yamaha dealer.

Trouble	Engine vibrates excessively.	
Item	Question	Answer
Propeller	Is propeller damaged?	Have propeller repaired or replaced.
	Are weeds or other foreign material tangled on propeller?	Remove and clean propeller.
Propeller shaft	Is propeller shaft damaged?	Have serviced by a Yamaha dealer.
Outboard motor mounting	Are outboard motor mounting bolts loose?	Tighten bolts or have serviced by a Yamaha dealer.
Steering pivot	Is steering pivot loose or damaged?	Have serviced by a Yamaha dealer.

Trouble Recovery

EMU29434

Temporary action in emergency

EMU29442

Impact damage

EWM00871

⚠ WARNING

The outboard motor can be seriously damaged by a collision while operating or trailering. Damage could make the outboard motor unsafe to operate.

If the outboard motor hits an object in the water, follow the procedure below.

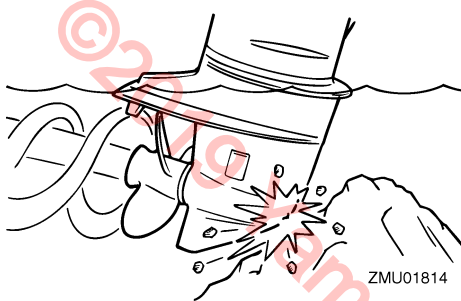

1. Stop the engine immediately.
2. Check the control system and all components for damage. Also, check the boat for damage.
3. Whether damage is found or not, return to the nearest harbor slowly and carefully.
4. Have a Yamaha dealer check the outboard motor before operating it again.

EMU42341

Running in an emergency (multiple engines)

Normally operate all outboard motors together for cruising. If any of the engines can not be operated for in case of emergency, be sure to keep the unused engine(s) tilted up and operate the other engine(s) at low speed.

ECM02511

NOTICE

If any of the engines can not be operated, be sure to tilt the unused engine(s) up. Otherwise water could enter the exhaust pipe due to the wave, causing engine trouble.

TIP:

When maneuvering at low speed, such as near a dock, it is recommended to tilt down the unused engine(s) and operate the unused engine(s) in neutral gear if possible.

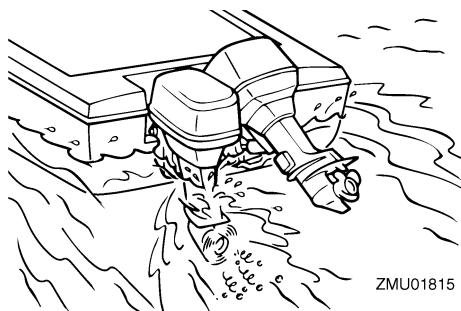

EMU29476

Replacing fuse

If a fuse has blown, remove the electrical cover, open the

fuse holder and remove the fuse with a fuse puller (if equipped). Replace it with a spare one of the proper amperage.

EWM00632

⚠ WARNING

Substituting an incorrect fuse or a piece of wire could allow excessive current flow. This could cause electric system damage and a fire hazard.

Consult your Yamaha dealer if the new fuse immediately blows again.

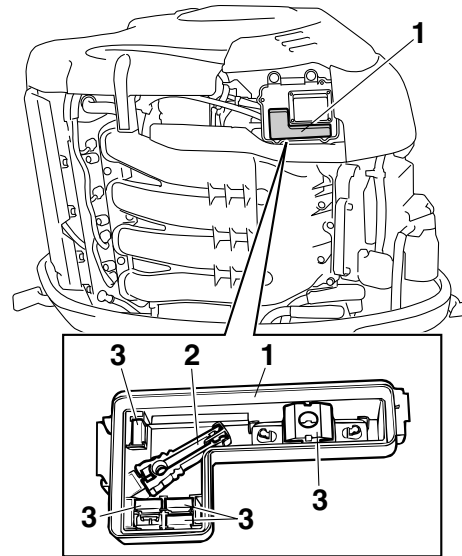

1. Electrical cover
2. Fuse puller
3. Spare fuse (10 A, 15 A, 20 A, 30 A, 60 A)

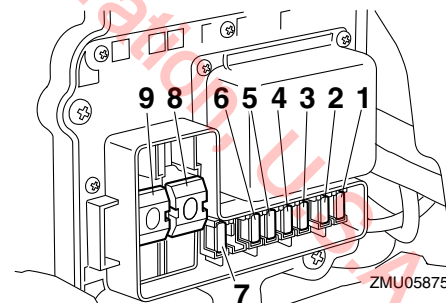

1. Fuel feed pump fuse (10 A)
2. Ignition coil / Fuel injector / Variable camshaft timing / Engine ECM (Electronic control module) fuse (30 A)
3. Fuel pump fuse (15 A)
4. Starting switch (30 A)
5. Main switch / PTT switch / Digital electronic control ECM (Electronic control module) fuse (20 A)
6. Shift actuator fuse (15 A)
7. Electric throttle valve fuse (10 A)
8. Engine main fuse (60 A)
9. Isolator fuse (60 A)

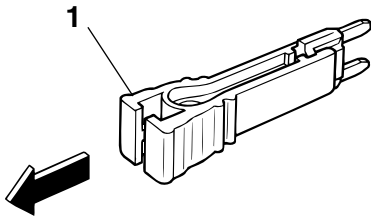

ZMU04337

1. Fuse puller

EMU35401

Power trim and tilt will not operate

If the engine cannot be tilted up or down with the power trim and tilt because of a discharged battery or a failure with the power trim and tilt unit, consult your Yamaha dealer.

EMU35614

Water separator-alert indicator blinks while cruising

EWWM01501

⚠ WARNING

Gasoline is highly flammable, and its vapors are flammable and explosive.

- Do not perform this procedure on a hot or running engine. Allow the engine to cool.
- There will be fuel in the fuel filter. Keep away from sparks, cigarettes, flames or other sources of ignition.
- This procedure will allow some fuel to spill. Catch fuel in a rag. Wipe up any spilled fuel immediately.
- The fuel filter must be reassembled carefully with the O-ring, filter cup, and hoses in place. Improper assembly or replacement could result in a fuel leak, which could result in a fire or explosion hazard.

If the water separator-alert indicator blinks, perform the following procedure.

1. Stop the engine.
2. Remove the top cowling.
3. Disconnect the lead from the holder.

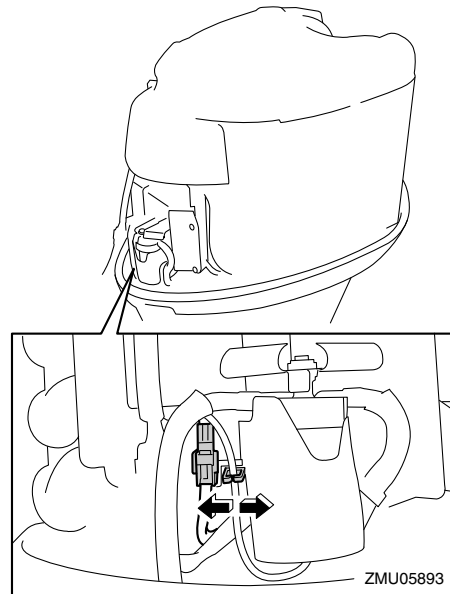

ZMU05893

4. Disconnect the water detection switch coupler from the holder.

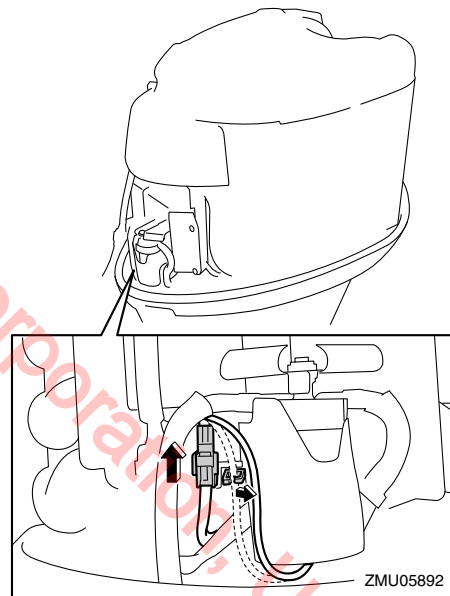

ZMU05892

5. Disconnect the water detection switch coupler. **NOTICE:** Be careful not to get any water on the water detection switch coupler, otherwise a malfunction could occur. [ECM01951]

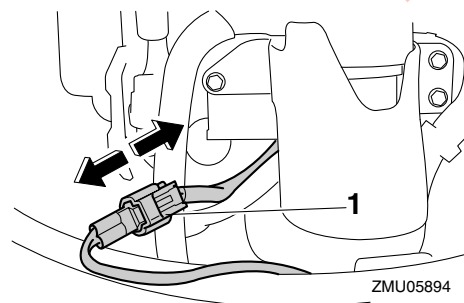

ZMU05894

1. Water detection switch coupler

Trouble Recovery

6. Remove the bolts to remove the cover.

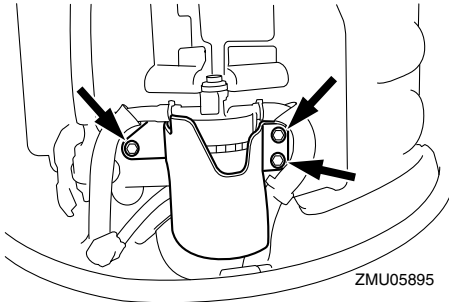

7. Unscrew the filter cup from the filter housing. **NOTICE:** Be careful not to twist the water detection switch lead when unscrewing the filter cup. [ECM01961]

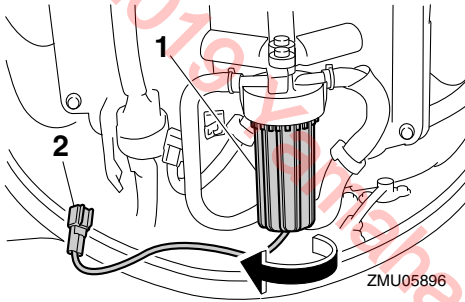

- 1. Filter cup
- 2. Water detection switch lead

8. Drain the water in the filter cup by soaking it up with a rag.

9. Firmly screw the filter cup onto the filter housing. **NOTICE:** Be careful not to twist the water detection switch lead when screwing the filter cup onto the filter housing. [ECM01971]

10. Install the cover, and tighten the bolts.

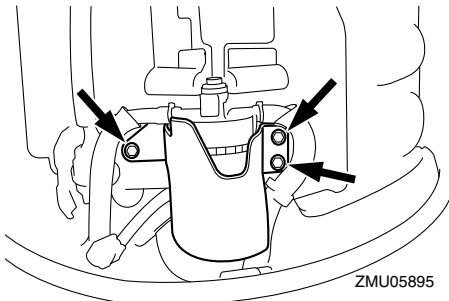

Bolt tightening torque:
8 Nm (0.82 kgf-m, 5.9 ft-lb)

11. Connect the water detection switch coupler securely until a click is heard.

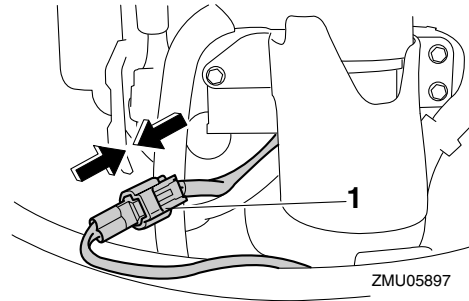

- 1. Water detection switch coupler
- 12. Securely attach the water detection switch coupler to the holder.
- 13. Connect the lead to the holder.

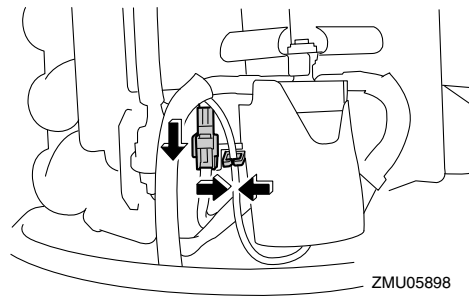

- 14. Install the top cowling.
- 15. Start the engine and make sure that the water separator-alert indicator remains off. Have a Yamaha dealer inspect the outboard motor after returning to port.

EMU33502

Treatment of submerged motor

If the outboard motor is submerged, immediately take it to a Yamaha dealer. Otherwise some corrosion may begin almost immediately. **NOTICE:** Do not attempt to run the outboard motor until it has been completely inspected.

[ECM00402]

Consumer information (For North America)

EMU29837

YAMAHA FOUR-STROKE OUTBOARD MOTOR THREE-YEAR LIMITED WARRANTY

Yamaha Motor Corporation, U.S.A. and Yamaha Motor Canada Ltd. ("Yamaha") hereby warrant that new Yamaha four-stroke outboard motors will be free from defects in material and workmanship for the period of time stated herein, subject to certain stated limitations.

PERIOD OF WARRANTY. Any new Yamaha four-stroke outboard motor purchased from an authorized Yamaha dealer in the customer's country of residence (United States or Canada) and registered with Yamaha will be warranted against defects in material or workmanship, subject to exclusions noted herein, for the following applicable period determined by type of use:

- Pleasure use – three (3) years from the date of purchase.
- Commercial application – one (1) year from the date of purchase. A commercial application is defined as any use of the outboard motor to generate income (excluding tournament fishing) or support business operations in any way during the warranty period, without regard to the type or percentage of commercial use. Yamaha reserves the right to modify incorrect registration data and reduce the warranty period to reflect commercial use.
- Yamaha peripheral equipment included with the motor, such as gauges, fuel tanks, and hoses, remote control boxes, and wiring external from the motor unit, will be warranted for one (1) year from the date of purchase for either pleasure or commercial use. Replacement parts used in warranty repairs will be warranted for the balance of the applicable warranty period.

The second and third year of warranty (if applicable) shall be limited to covering the cost of parts and labor for major components only. The major components covered are:

Power Unit Section

- Power Head
- Intake Manifold
- Carburetor Assembly and its Related Components
- Fuel Injection System and its Related Components
- Fuel and Oil Pump Assemblies
- Ignition System (Standard and Microcomputer)

Lower Unit Section Bracket Section

- Exhaust System
- Bracket System
- Upper Casing
- Power Trim and Tilt Assembly
- Lower Unit Assembly

WARRANTY REGISTRATION. To be eligible for warranty coverage, the outboard motor must be registered with Yamaha in the country of residence. Warranty registration can be accomplished by any authorized Yamaha Outboard Motor Dealer.

OBTAINING REPAIRS UNDER WARRANTY. During the period of warranty, any authorized Yamaha Outboard Motor Dealer in the country of residence will, free of charge, repair or replace, at Yamaha's option, any parts adjudged defective by Yamaha due to faulty workmanship or material from the factory. All replaced parts will become the property of Yamaha. If the customer is temporarily using a U.S.-registered outboard motor in Canada, or a Canada-registered outboard motor in the United States, and it needs warranty repairs, the owner should contact a nearby authorized Yamaha Outboard Motor Dealer for assistance. The local dealer will contact Yamaha on the owner's behalf so that needed repairs can be made as quickly as possible.

CUSTOMER'S RESPONSIBILITY. Under the terms of this warranty, the customer will be responsible for ensuring that the outboard motor is properly operated, maintained, and stored as specified in the applicable Owner's Manual. The owner of the outboard motor shall give notice to an authorized Yamaha Outboard Motor Dealer of any and all apparent defects within ten (10) days of discovery and make the motor available at that time for inspection and repairs at the dealer's place of business.

ZMU07048

Consumer information (For North America)

GENERAL EXCLUSIONS FROM WARRANTY. This warranty will not cover the repair of damage if the damage is a result of abuse or neglect of the product. Examples of abuse and neglect include, but are not limited to:

1. Racing or competition use, modification of original parts, abnormal strain.
2. Lack of proper maintenance and off season storage as described in the Owner's Manual; installation of parts or accessories that are not equivalent in design and quality to genuine Yamaha parts.
3. Operation of the motor at an rpm other than specified, use of lubricants or oils that are not suitable for outboard motor use.
4. Damage as a result of accidents, collisions, contact with foreign materials, or submersion.
5. Growth of marine organism on motor surfaces.
6. Normal deterioration.

SPECIFIC PARTS EXCLUDED FROM WARRANTY. Parts replaced due to normal wear or routine maintenance such as oil, spark plugs, shear pins, propellers, hubs, fuel and oil filters, brushes for the starter motor and power tilt motor, water pump impellers, and anodes, are not covered by warranty. Charges for removal of the motor from a boat and transporting the motor to and from an authorized Yamaha Outboard Motor Dealer are excluded from warranty coverage.

Specific parts excluded from the second and third year of warranty (if applicable) are:

- Top and Bottom Cowling
- Electric Components (other than ignition system)
- Rubber Components (such as hoses, tubes, rubber seals, fittings, and clamps)

EMISSION CONTROL WARRANTY (United States only). Yamaha warrants to the ultimate purchaser and any subsequent owner, that the emission control components on this engine are designed, built and equipped so as to conform at the time of sale with applicable regulations under section 213 of the Clean Air Act and that this engine is covered against defects in materials and workmanship which cause said engine to fail to conform with applicable exhaust emission regulations for five (5) years from the date of purchase or 175 hours of operation, whichever comes first. Evaporative components (e.g., hoses, fuel tank, fuel cap) are two (2) years from the date of purchase. Some states have different emission control warranty provisions. As these vary from state to state, consult your Yamaha dealer or contact Yamaha Customer Relations at 1-866-894-1626 for more information.

TRANSFER OF WARRANTY Transfer of the warranty from the original purchaser to any subsequent purchaser is possible by having the motor inspected by an authorized Yamaha Outboard Motor Dealer and requesting the dealer to submit a change of registration to Yamaha within ten (10) days of the transfer.

YAMAHA MAKES NO OTHER WARRANTY OF ANY KIND, EXPRESSED OR IMPLIED. ALL IMPLIED WARRANTIES OF MERCHANTABILITY AND FITNESS FOR A PARTICULAR PURPOSE WHICH EXCEED THE OBLIGATIONS AND TIME LIMITS STATED IN THIS WARRANTY ARE HEREBY DISCLAIMED BY YAMAHA AND EXCLUDED FROM THIS WARRANTY. SOME STATES/PROVINCES DO NOT ALLOW LIMITATIONS ON HOW LONG AN IMPLIED WARRANTY LASTS, SO THE ABOVE LIMITATIONS MAY NOT APPLY TO YOU. ALSO EXCLUDED FROM THIS WARRANTY ARE ANY INCIDENTAL OR CONSEQUENTIAL DAMAGES INCLUDING LOSS OF USE. SOME STATES/PROVINCES DO NOT ALLOW THE EXCLUSION OR LIMITATION OF INCIDENTAL OR CONSEQUENTIAL DAMAGES, SO THE ABOVE EXCLUSION MAY NOT APPLY TO YOU.

THIS WARRANTY GIVES YOU SPECIFIC LEGAL RIGHTS, AND YOU MAY ALSO HAVE OTHER RIGHTS WHICH VARY FROM STATE TO STATE/PROVINCE TO PROVINCE.

ZMU07047

Consumer information (For North America)

EMU29846

IMPORTANT WARRANTY INFORMATION IF YOU USE YOUR YAMAHA OUTSIDE THE U.S.A. OR CANADA

Welcome to the Yamaha Family!

Congratulations on the purchase of your new Yamaha products. Yamaha is committed to exceptional customer satisfaction and we want your ownership experience to be a satisfying one. Please read the following warranty information to help ensure satisfaction with your Yamaha.

This model was manufactured with specifications appropriate for sale and use in the U.S.A. and Canada. Please note the following information:

1. As explained in the Limited Warranty Statement, the Yamaha warranty covers your Yamaha when it is registered and used in your country of residence. If you are temporarily using a U.S.-registered outboard motor in Canada, or a Canada-registered outboard motor in the United States, and it needs warranty repairs, you should contact a nearby authorized Yamaha Outboard Motor Dealer for assistance. The local dealer will contact Yamaha on the owner's behalf so that needed repairs can be made as quickly as possible.
2. If you need repairs while temporarily using your Yamaha in another country, contact the local authorized Yamaha distributor for that country. Yamaha will work with that distributor to make the needed repairs as quickly as possible. If you have to pay for a repair that you believe your warranty would have covered at home, present all repair orders, receipts, or other related documents to your local dealer when you return home. He will be able to contact Yamaha on your behalf to see if any refund can be provided.

TIP:

Your Yamaha model may not be sold in some countries. Therefore, a Yamaha dealer outside the United States or Canada may not have all of the replacement parts or technical information available to provide proper service. This may unavoidably delay repairs. Thank you for your understanding should this happen.

3. If your Yamaha is registered or used primarily outside the United States or Canada, the warranty printed in this manual does not apply to you. Contact the dealer who sold the Yamaha marine power unit to you for customer support information.

ZMU05199

INDEX

6	6Y8 Multifunction meters.....	34	Engine oil.....	42
	6Y9 Multifunction Color Gauge	30	Engine oil requirements.....	14
	6YC Multifunction meter	32	Engine oil, changing	68
A			Engine oil, filling	41
	Accident reporting	2	Engine selector switch.....	25
	Alcohol and drugs.....	1	Engine shut-off cord (lanyard)	1, 42
	Alert system.....	37	Engine shut-off cord (lanyard) and clip.....	25
	All Start/Stop switch panel.....	27	Engine synchronization indicator.....	30
	Anode(s), inspecting and replacing	70	Engine trouble alert	32
	Anti-fouling paint.....	15	Engine warm-up indicator.....	30
	Approval label of emission control certificate	16	Engine, checking	43
	Avoid collisions.....	2		
B			F	
	Basic boating rules (Rules of the road)	3	Filling fuel	44
	Battery	44	First-time operation	41
	Battery requirements.....	13	Flushing device	28, 43
	Battery, checking (electric start models)	71	Flushing power unit	62
	Battery, connecting.....	71	Free throttle switch.....	23
	Battery, disconnecting.....	72	Fuel filter.....	29
	Battery, storing	72	Fuel filter, checking	42
	Boat direction	53	Fuel leaks, checking for.....	42
	Boat education and training.....	2	Fuel level	41
	Boat horsepower rating	13	Fuel requirements	14
	Boating organizations.....	2	Fuel system	42
	Boating safety.....	1	Fuse, replacing	75
	Boating safety publications.....	2		
	Breaking in engine.....	41	G	
C			Gasoline	1, 14
	Carbon monoxide.....	1	Gasoline Additives.....	15
	CE Marking.....	7	Gasoline exposure and spills	1
	Checks after engine warm up.....	47	Gear oil, changing	69
	Checks after starting engine.....	47	Greasing.....	66
	Checks before starting engine.....	41		
	Cleaning and anticorrosion measures.....	62	H	
	Cleaning the outboard motor.....	61	Hot parts.....	1
	Compliance mark and manufactured date label.....	7		
	Components diagram	18	I	
	Control functions, checking	42	Identification numbers record	6
	Cooling water	47	Impact damage.....	75
	Cowling lock lever	28	Installation requirements	13
D				
	De-activating the engine speed control system.....	60	K	
	Digital electronic control	21	Key number.....	6
	Digital Electronic Control alert	37		
	Digital electronic control requirements	13	L	
	Digital electronic control serial number	6	Laws and regulations	2
	Digital electronic control-active indicator.....	21	Low battery voltage-alert.....	31
	Digital electronic control-alert indicator	22	Low oil pressure alert	38
			Low oil pressure-alert	31
E			Lubrication	61
	EC Declaration of Conformity (DoC)	7		
	Electric shock	1	M	
	Emergency equipment	16	Main switch.....	26
	Emergency, running in an	75	Maintenance chart 1	64
	Emergency, temporary action in.....	75	Maintenance chart 2.....	65
	Emission control information	16	Maintenance chart 3.....	65
	Engine idle speed, inspecting.....	67	Maintenance interval guidelines	63
			Modifications	1
			Mounting height.....	40
			Mounting motor	13
			Mounting the outboard motor	40

N	Neutral interlock trigger	23	Tilt support lever	28
O	Operating engine	45	Tilting up and down	57
	Operating in salt water or other conditions	60	Top cowling, installing	43
	Operating the port / center / starboard engine	50	Top cowling, removing	41
	Outboard motor (painted surface), checking	62	Transporting and storing outboard motor	61
	Outboard motor disposal requirements	16	Trimming outboard motor	56
	Outboard motor safety	1	Trolling	55
	Outboard motor serial number	6	Troubleshooting	73
	Outboard motor, selecting	48	W	
	Overheat alert	30, 37	Warming up engine	47
	Overloading	2	Warning labels	9
P			Warranty information (use outside the U.S.A. or Canada)	80
	Passenger training	2	Warranty, limited	78
	Passengers	1	Water separator alert	31, 39
	People in the water	1	Water separator-alert indicator blinks while cruising	76
	Periodic maintenance	62	Weather	2
	Personal flotation devices (PFDs)	1	Wiring and connectors, inspecting	68
	Power trim and tilt	1	Y	
	Power trim and tilt switch (bottom cowling)	27	Yamaha Security System (Y-COP)	21
	Power trim and tilt switch (digital electronic control)	27	Yamaha Security System indicator (optional)	30
	Power trim and tilt switches	27		
	Power trim and tilt system, checking	44		
	Power trim and tilt will not operate	76		
	Propeller	1		
	Propeller (counter rotation models)	14		
	Propeller selection	14		
	Propeller, checking	68		
	Propeller, installing	69		
	Propeller, removing	68		
R				
	Read manuals and labels	9		
	Remote control lever	22		
	Replacement parts	62		
	Rotating parts	1		
	Rules when encountering vessels	3		
S				
	Sending fuel	45		
	Shallow water	59		
	Shifting	49		
	Shifting (checks after engine warm up)	47		
	Spark plug, inspecting	66		
	Specifications	12		
	Star labels	16		
	Start/Stop switch panel	26		
	Starting engine	45		
	Start-in-gear protection	14		
	Steering and sailing rules and sound signals	3		
	Stop switches	47		
	Stopping boat	50		
	Stopping engine	55		
	Storing outboard motor	61		
	Submerged outboard motor	77		
T				
	Throttle friction adjuster	24		
	Tilt limiter	28		

©2019 Yamaha Motor Corporation, U.S.A.

For your best ownership experience, think **Genuine Yamaha!**

Genuine Yamaha Parts — Genuine Yamaha replacement parts are the exact same parts as the ones originally equipped on your vehicle, providing you with the performance and durability you have come to expect. Why settle for aftermarket parts that may not provide full confidence and satisfaction?

Genuine Yamaha Accessories — Yamaha only offers accessories that meet our high standards for quality and performance. Buy with confidence, knowing your Genuine Yamaha Accessories will fit right and perform right — right out of the box.

Yamalube — Take care of your Yamaha with legendary Yamalube oils, lubricants, and care products. They're formulated and approved by the toughest judges we know: the Yamaha engineering teams that know your Yamaha from the inside out.

Genuine Yamaha Service Manuals — Get the same factory manual for your vehicle that the technicians at your authorized Yamaha dealer use. Service manuals are available through your Yamaha dealer or you can order them directly through yamaha-hapubs.com (USA only).

Genuine Yamaha products are available only from your Yamaha dealer.

Find out more at www.yamaha-motor in your country of residence.

©2019 Yamaha Motor Corporation, U.S.A.

©2019 Yamaha Motor Corporation, U.S.A.

